

DTC	P0120/31,41*	Throttle Position Sensor Circuit Malfunction
------------	---------------------	---

*: ETCS trouble code No.31

CIRCUIT DESCRIPTION

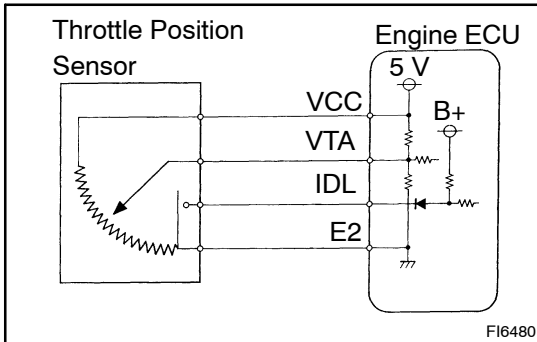

The throttle position sensor is mounted in the throttle body and detects the throttle valve opening angle.

When the throttle valve opening angle is less than 5° , the IDL contacts in the throttle position sensor are on, so the voltage at the terminal IDL of the engine ECU becomes 0 V. At this time, a voltage of approximately 0.6 V is applied to terminal VTA of the engine ECU. When the throttle valve is opened, the IDL1 contacts go off and thus the power source voltage of approximately 12 V in the engine ECU is applied to the terminal IDL of the engine ECU. The voltage applied to the terminal VTA of the engine ECU increases in proportion to the opening angle of the throttle valve and becomes approximately 3.2 – 4.9 V when the throttle valve is fully opened. The engine ECU judges the vehicle driving conditions from these signals input from terminals VTA and IDL, and uses them as one of the conditions for deciding the air-fuel ratio correction, power increase correction and fuel-cut control etc.

DTC No.	DTC Detecting Condition	Trouble Area
P0120/31, 41	Condition (a) or (b) continues: (a) VTA1 < 0.25 V, and closed throttle position switch is OFF (b) VTA1 \geq 4.9 V	<ul style="list-style-type: none"> • Open or short in throttle position sensor circuit • Throttle position sensor • Engine ECU

HINT:

- If there is open circuit in IDL1 line, DTC P0120 does not indicate.
- After confirming DTC P0120, use the hand-held tester to confirm the throttle valve opening percentage and closed throttle position switch condition.

Throttle valve opening position expressed as percentage		Trouble Area
Throttle valve fully closed	Throttle valve fully open	
0 %	0 %	VCC line open VTA line open or short
Approx. 100 %	Approx. 100 %	E2 line open

WIRING DIAGRAM

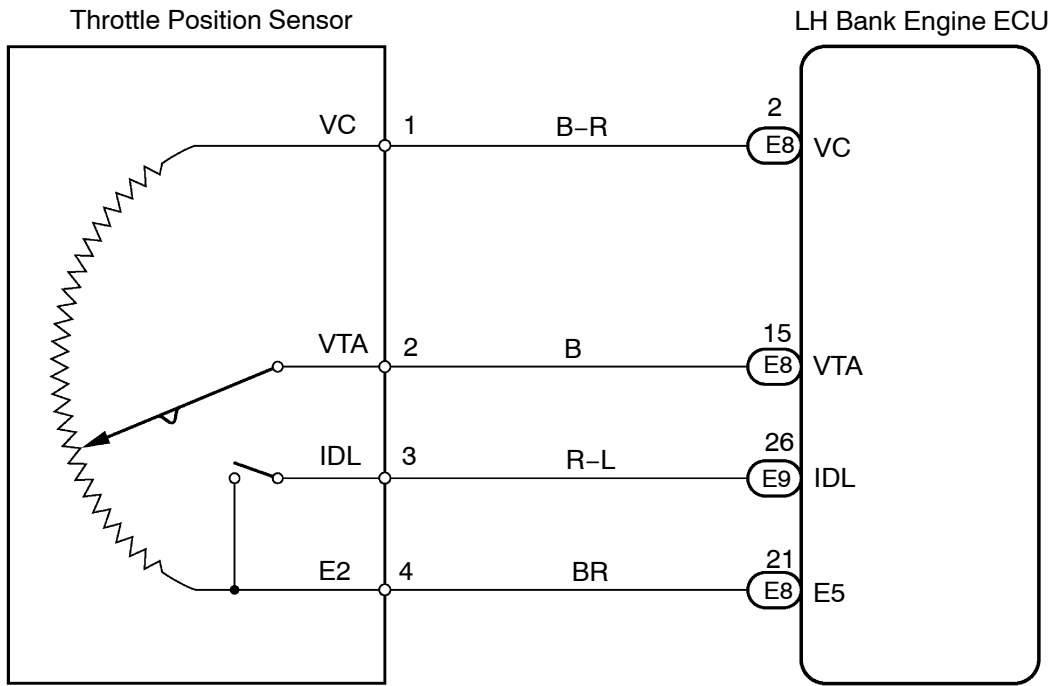

N

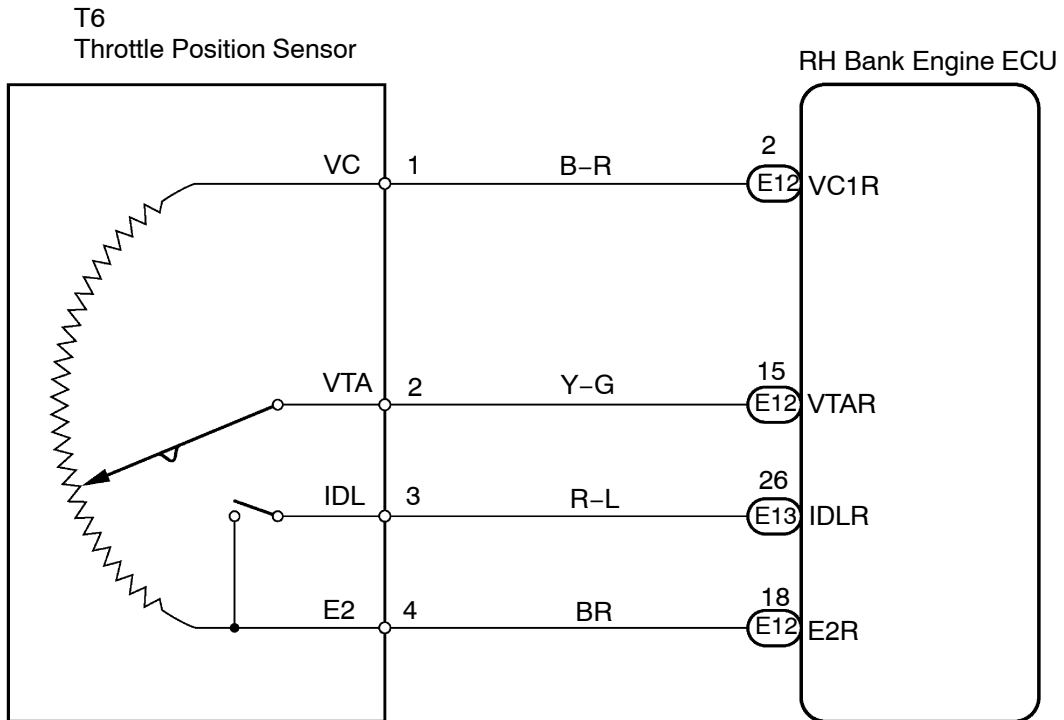

A08142

N

A08234

INSPECTION PROCEDURE

HINT:

- LH and RH bank engine ECU detect this DTC code respectively. The inspection procedures are same for both LH and RH bank engine ECU and described in this manual. Even though terminal name and part name on the side of RH bank are described in parenthesis, perform the inspection for only ECU that has detected DTC.
- LH Bank:
If DTC P0115/22 (Water Temp. Circuit Malfunction), P0120/41 (Throttle Position Sensor Circuit Malfunction) are output simultaneously, E5 (Sensor Ground) may be open.
- RH Bank:
If DTC P0110/24 (Intake Air Temp. Circuit Malfunction), P0120/41 (Throttle Position Sensor Circuit Malfunction) are output simultaneously, E2R (Sensor Ground) may be open.
- Read freeze frame data using hand-held tester. Because freeze frame records the engine conditions when the malfunction is detected, when troubleshooting it is useful for determining whether the vehicle was running or stopped, the engine warmed up or not, the air-fuel ratio lean or rich, etc. at the time of the malfunction.

When using hand-held tester

1 Connect hand-held tester, read throttle valve opening percentage.

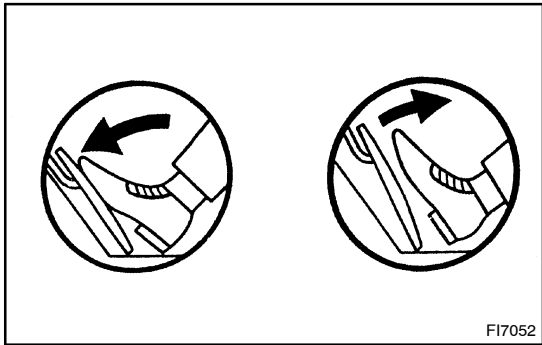

PREPARATION:

- (a) Connect the hand-held tester to DLC3.
- (b) Turn the ignition switch to ON and switch the hand-held tester main switch to ON.
- (c) Start the engine.

CHECK:

Read the throttle valve opening percentage.

OK:

Throttle valve	Throttle valve opening position expressed as percentage
Fully open	Approx. 70 %
Fully closed	Approx. 10 %

OK Check and replace engine ECU (See page IN-20).

NG

2 Check voltage between terminals VC (VC1R) and E5 (E2R) of engine ECU connector.

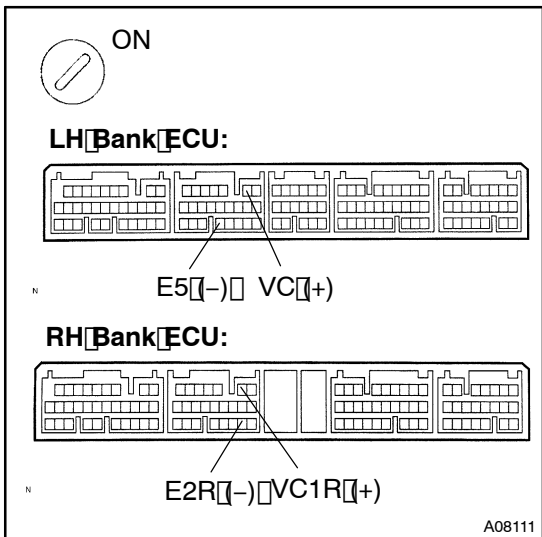

PREPARATION:

- (a) Remove the engine ECU with connectors still connected.
- (b) Turn the ignition switch to ON.

CHECK:

Measure voltage between terminals VC (VC1R) and E5 (E2R) of the engine ECU connector.

OK:

Voltage: 4.5 – 5.5 V

NG Check and replace engine ECU (See page IN-20).

OK

3 Check voltage between terminals VTA (VTAR) and E5 (E2R) of engine ECU connector.

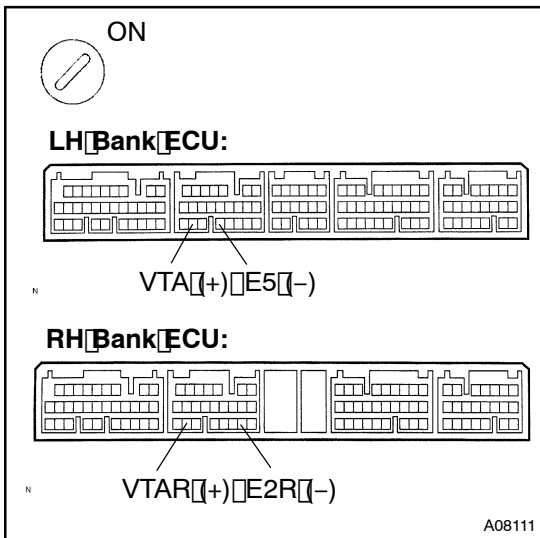

PREPARATION:

- (a) Remove the engine ECU with connectors still connected.
(b) Start the engine.

CHECK:

Measure voltage between terminals VTA (VTAR), and E5 (E2R) of the engine ECU connector.

OK:

Accelerator pedal	Voltage
Released	VTA (VTAR) 0.3 - 0.8 V
Depressed	3.2 - 4.9 V

OK

Check and replace engine ECU (See page IN-20).

NG

4 Check throttle position sensor (See Pub. No. RM677E, page FI-30).

NG

Replace throttle body assembly.

OK

Check for open and short in harness and connector between engine ECU and throttle position sensor (VC, VTA, E5 line) (See page IN-20).

When not using hand-held tester

- 1 Check voltage between terminals VC (VC1R) and E5 (E2R) of engine ECU connector.

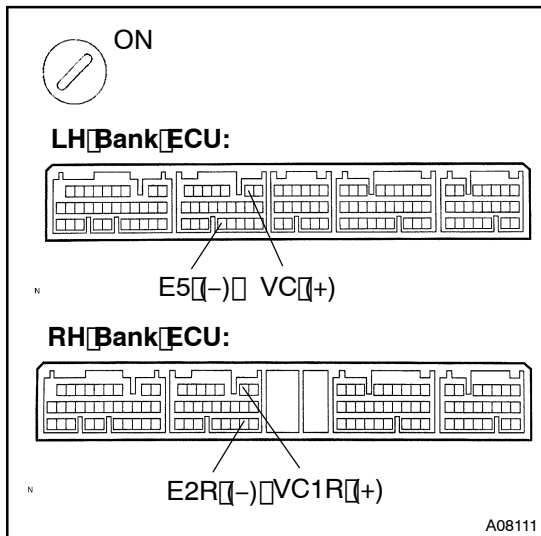

PREPARATION:

- (a) Remove the engine ECU with connectors still connected.
(b) Turn the ignition switch to ON.

CHECK:

Measure voltage between terminals VC (VC1R) and E5 (E2R) of the engine ECU connector.

OK:

Voltage: 4.5 – 5.5 V

NG

Check and replace engine ECU (See page IN-20).

OK

- 2 Check voltage between terminals VTA (VTAR) and E5 (E2R) of engine ECU connector.

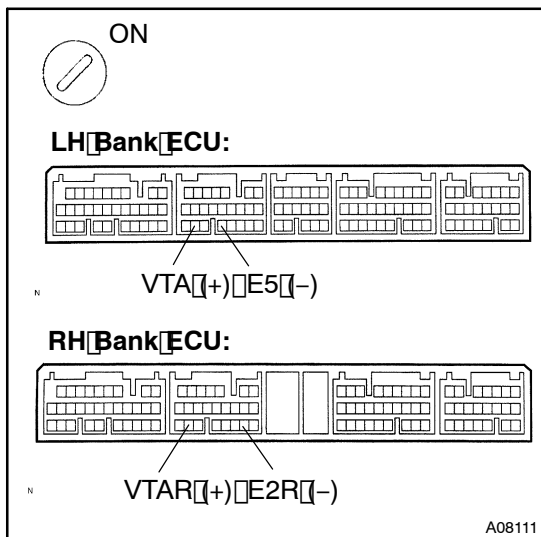

PREPARATION:

- (a) Remove the engine ECU with connectors still connected.
(b) Start the engine.

CHECK:

Measure voltage between terminals VTA (VTAR) and E5 (E2R) of the engine ECU connector.

OK:

Throttle valve position	Voltage
	VTA (VTAR)
Fully closed	0.3 – 0.8 V
Fully open	3.2 – 4.9 V

OK

Check and replace engine ECU (See page IN-20).

NG

3 Check throttle position sensor (See Pub. No. RM677E, page FI-30).

NG

Replace throttle body assembly.

OK

Check for open and short in harness and connector between engine ECU and throttle position sensor (See page IN-20).