

## DISPOSAL

### HINT:

When scrapping vehicles equipped with an SRS or disposing of the front side airbag assembly always first deploy the airbag in accordance with the procedure described below. If any abnormality occurs with the airbag deployment, contact the SERVICE DEPT. of the DISTRIBUTOR.

### CAUTION:

- Never dispose of a front side airbag assembly which has an undeployed airbag.
- The airbag produces a sizeable exploding sound when it deploys, so perform the operation out of doors and where it will not create a nuisance to nearby residents.

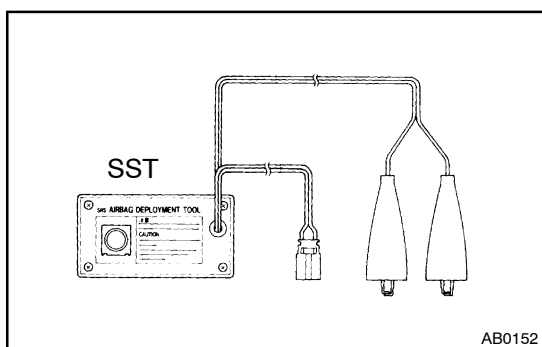

- When deploying the airbag, always use the specified SST (SRS Airbag Deployment Tool), perform the operation in a place away from electrical noise.  
SST 09082-00700
- When deploying an airbag, perform the operation at least 10 m (33 ft) away from the airbag assembly.
- The front side airbag assembly is very hot when the airbag is deployed, so leave it alone for at least 30 minutes after deployment.
- Use gloves and safety glasses when handling front side airbag assembly with the deployed airbag.
- Always wash your hands with water after completing the operation.
- Do not apply water, etc. to a front side airbag assembly with the deployed airbag.

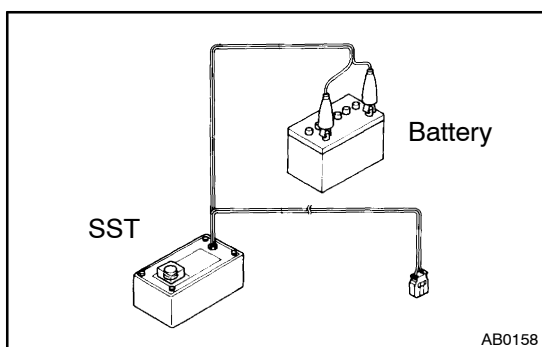

## 1. AIRBAG DEPLOYMENT WHEN SCRAPPING VEHICLE

### HINT:

Have a battery ready as the power source to deploy the airbag.

- (a) Check functioning of the SST.

(See step 1-(a) on page RS-16)

SST 09082-00700

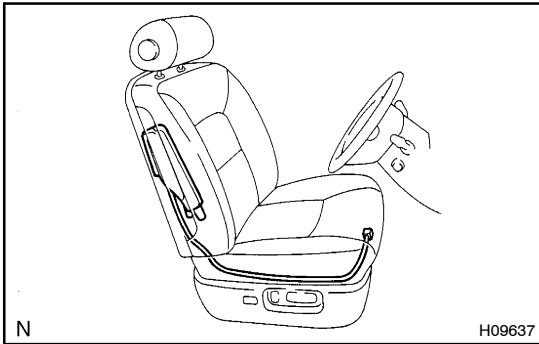

(b) Disconnect the front side airbag connector.

**NOTICE:**

**When handling the airbag connector, take care not to damage the airbag wire harness.**

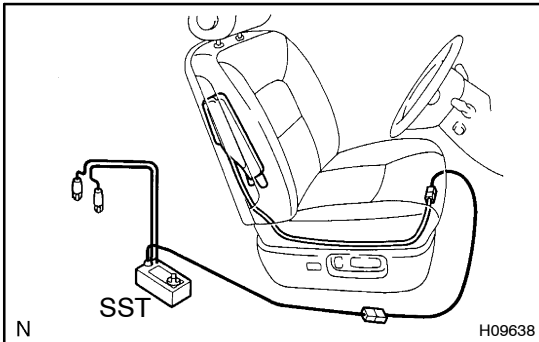

(c) Install the SST.

(1) Connect the connector of 2 SST to the airbag connector.

SST 09082-00700, 09082-00750

**NOTICE:**

**To avoid damaging the SST connector and wire harness, do not lock the secondary lock of the twin lock.**

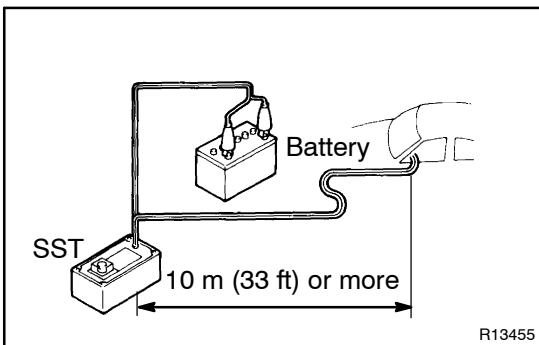

(2) Move the SST at least 10 m (33 ft) away from the front of the vehicle.

(3) Close all the doors and windows of the vehicle.

**NOTICE:**

**Take care not to damage the SST wire harness.**

(4) Connect the SST red clip to the battery positive (+) terminal and the black clip to the battery negative (-) terminal.

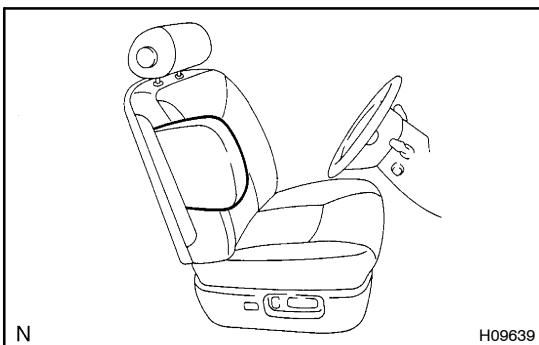

(d) Deploy the airbag.

(1) Check that no one is inside the vehicle or within 10 m (33 ft) area around the vehicle.

(2) Press the SST activation switch and deploy the airbag.

**HINT:**

The airbag deploys simultaneously as the LED of SST activation switch lights up.

(e) Dispose of front side airbag assembly.

**CAUTION:**

- **The front side airbag assembly is very hot when the airbag is deployed, so leave it alone for at least 30 minutes after deployment.**
- **When moving a vehicle for scrapping which has a front side airbag assembly with deployed airbag, use gloves and safety glasses.**
- **Use gloves and safety glasses when handling a front side airbag assembly with the deployed airbag.**
- **Do not apply water, etc. to a front side airbag assembly with the deployed airbag.**

- **Always wash your hands with water after completing the operation.**

HINT:

When scrapping a vehicle, deploy the airbag and scrap the vehicle with the front side airbag assembly still installed.

## 2. DEPLOYMENT WHEN DISPOSING OF FRONT SIDE AIRBAG ASSEMBLY

NOTICE:

- **When disposing of the side airbag assembly only, never use the customer's vehicle to deploy the airbag.**
- **Be sure to follow the procedure given below when deploying the airbag.**

HINT:

Have a battery ready as the power source to deploy the airbag.

- Remove the seatback assembly. (See page RS-38)
- Remove the front side airbag assembly from the seatback assembly.

CAUTION:

**Store the front side airbag assembly with the airbag deployment side facing upward.**

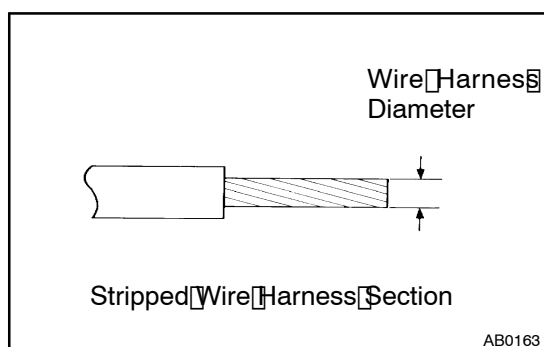

- Using a service-purpose wire harness tie down the front side airbag assembly.

**Wire harness: Stripped wire harness section  
1.25 mm<sup>2</sup> or more (0.0019 in<sup>2</sup> or more)**

CAUTION:

**If a wire harness which is too thin or some other thing is used to tie down the front side airbag assembly, it may be snapped by the shock when the airbag is deployed. This is highly dangerous. Always use a wire harness for vehicle use which is at least 1.25 mm<sup>2</sup> (0.0019 in<sup>2</sup>).**

HINT:

To calculate the square of the stripped wire harness section:

**Square = 3.14 x (Diameter)<sup>2</sup> divided by 4**

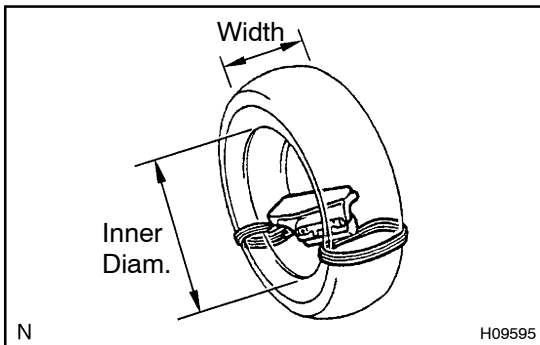

Position the front side airbag assembly inside the tire with the airbag deployment direction facing inside.

**Tire size must exceed the following dimensions:-**  
**Width 185 mm (7.28 in.)**

**Inner diameter 360 mm (14.17 in.)**

**CAUTION:**

- Make sure the wire harness is tight. It is very dangerous when a loose wire harness results in the front side airbag assembly coming free due to the shock from the airbag deploying.
- Always tie down the front side airbag assembly with the airbag door facing inside.

**NOTICE:**

The tire will be marked by the airbag deployment, so when disposing of the airbag use a redundant tire.

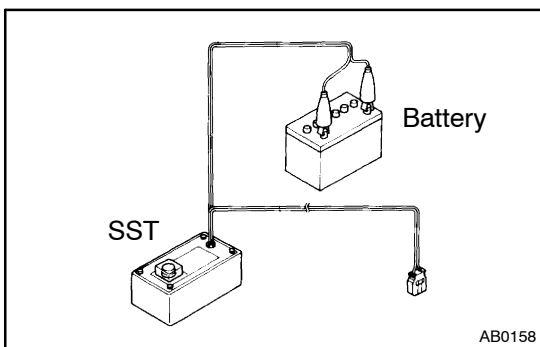

(d) Check functioning of the SST.

(See step 1-(a) on [page RS-16](#))

SST 09082-00700

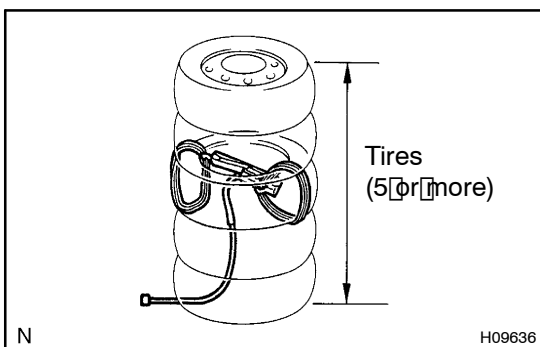

(e) Place the tires.

- (1) Place at least 2 tires under the tire to which the front side airbag assembly is tied.
- (2) Place at least 2 tires over the tire to which the side airbag assembly is tied. The top tire should have the wheel installed.

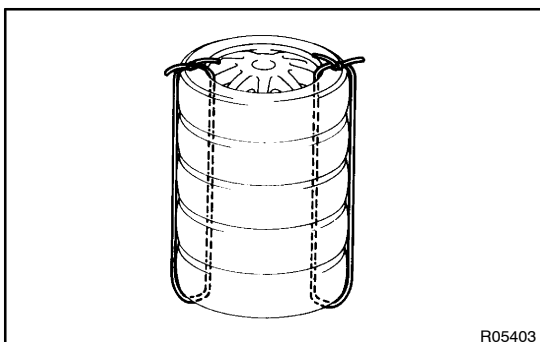

(3) Tie the tires together with the 2 wire harness.

**CAUTION:**

**Make sure that the wire harness are tight. It is very dangerous when loose wire harness result in the tires coming free due to the shock from the airbag deploying.**

**HINT:**

Place the SST connector and wire harness inside tires. Secure at least 1 m (3 ft) of slack for the wire harness.

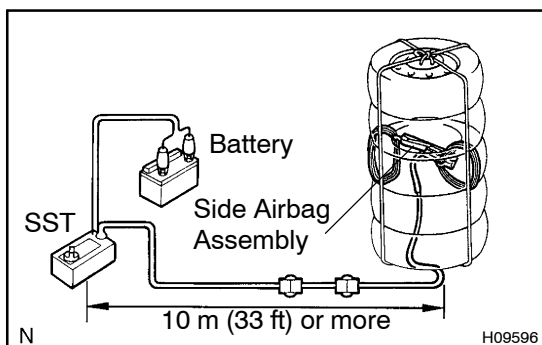

- (f) Install the SST.  
Connect the connector of 2 SST to the front side airbag assembly connector.  
SST 09082-00700, 09082-00750
- (g) Deploy the airbag.
- (1) Connect the SST red clip to the battery positive (+) terminal and the black clip to the battery negative (-) terminal.
  - (2) Check that no one is within 10 m (33 ft) area around the tire which the front side airbag assembly is tied to.
  - (3) Press the SST activation switch and deploy the airbag.

**HINT:**

The airbag deploys simultaneously as the LED of the SST activation switch lights up.

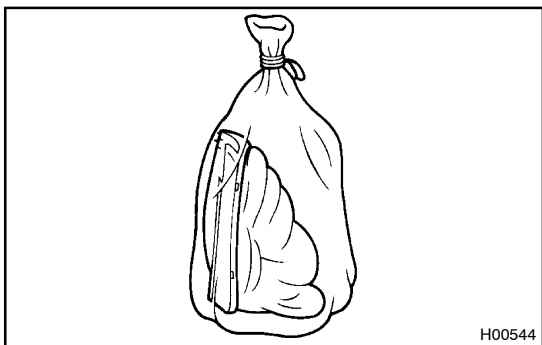

- (h) Dispose the front side airbag assembly.

**CAUTION:**

- **The front side airbag assembly is very hot when the airbag is deployed, so leave it alone for at least 30 minutes after deployment.**
  - **Use gloves and safety glasses when handling a front side airbag assembly with the deployed airbag.**
  - **Do not apply water etc. to a front side airbag assembly with the deployed airbag.**
  - **Always wash your hands with water after completing the operation.**
- (1) Remove the front side airbag assembly from the tire.
  - (2) Place the front side airbag assembly in a vinyl bag, tie the end tightly and dispose of it in the same way as other general parts disposal.

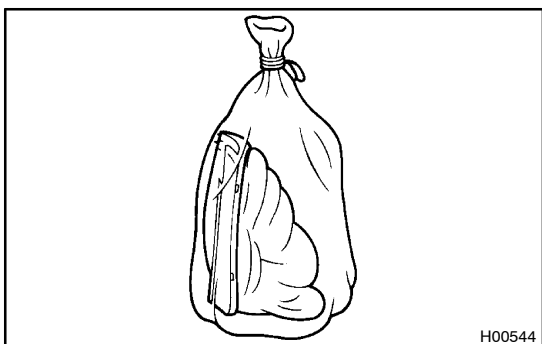

### 3. DEPLOYMENT WHEN DISPOSING OF FRONT SIDE AIRBAG ASSEMBLY WITH AN AIRBAG DEPLOYED IN A COLLISION

Dispose the front side airbag assembly.

**CAUTION:**

- **The front side airbag assembly is very hot when the airbag is deployed, so leave it alone for at least 30 minutes after deployment.**

- **When moving a vehicle for scrapping which has a front side airbag assembly with deployed airbag, use gloves and safety glasses.**
- **Use gloves and safety glasses when handling a front side airbag assembly with the deployed airbag.**
- **Do not apply water, etc. to a front side airbag assembly with the deployed airbag.**
- **Always wash your hands with water after completing the operation.**
  - (1) Remove the front side airbag assembly from the vehicle.
  - (2) Place the front side airbag assembly in a vinyl bag, tie the end tightly and dispose of it in the same way as other general parts disposal.