

DISASSEMBLY

NOTICE:

When using a vise, do not overtighten it.

1. REMOVE 2 TURN PRESSURE TUBES

Using SST, remove the 2 turn pressure tubes.

SST 09633-00020

SR0TY-01

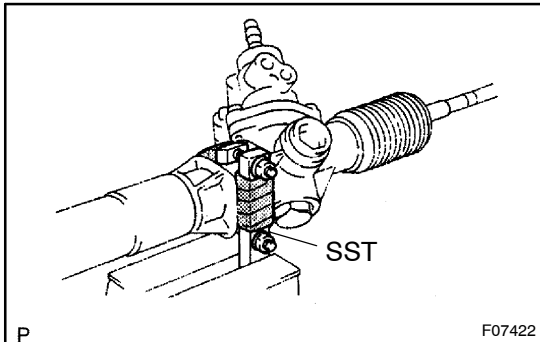

2. SECURE PS GEAR ASSEMBLY IN VISE

(a) Using SST, secure the PS gear assembly in a vise.

SST 09612-00012

(b) Remove the tube clamp.

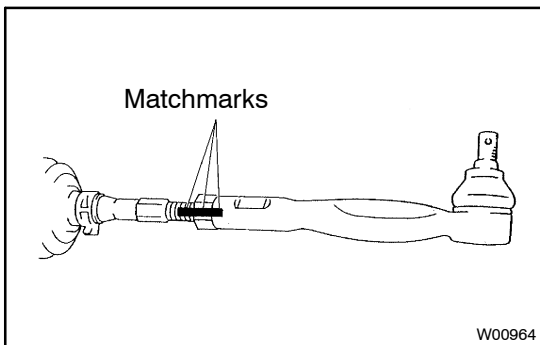

3. REMOVE RH AND LH TIE ROD ENDS AND LOCK NUTS

(a) Place matchmarks on the tie rod end and rack end.

(b) Loosen the lock nut and remove the tie rod end and lock nut.

(c) Employ the same manner described above to the other side.

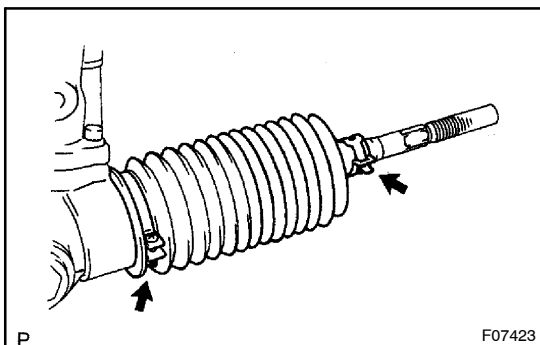

4. REMOVE RH AND LH CLIPS, RACK BOOTS AND CLAMPS

(a) Remove the screw and loosen the clamp.

NOTICE:

Be careful not to damage the boot.

(b) Remove the clip, clamp and rack boot.

HINT:

Mark the RH and LH rack boots.

(c) Employ the same manner described above to the other side.

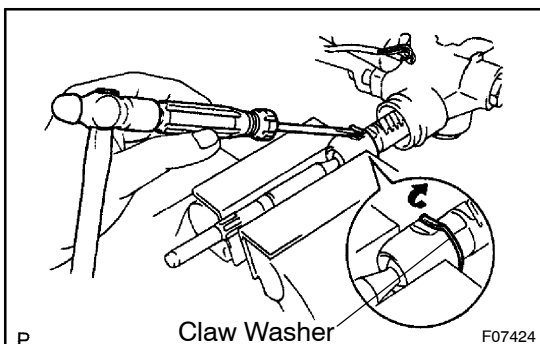

5. REMOVE RH AND LH RACK ENDS AND CLAW WASHERS

(a) Using a screwdriver and hammer, unstake the washer.

NOTICE:

Avoid any impact on the steering rack.

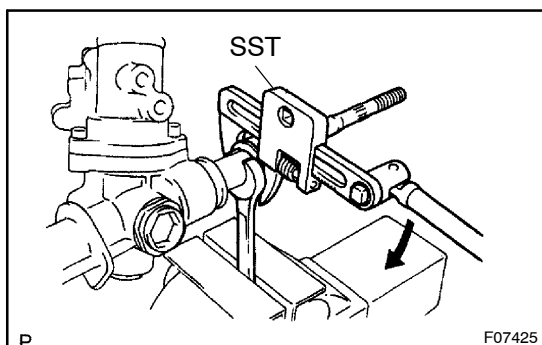

- (b) Using a wrench, hold the steering rack steadily and using SST, remove the rack end.
SST 09922-10010

NOTICE:

Use SST 09922-10010 in the direction shown in the illustration.

HINT:

Mark the RH and LH rack ends.

- (c) Remove the claw washer.
(d) Employ the same manner described above to the other side.

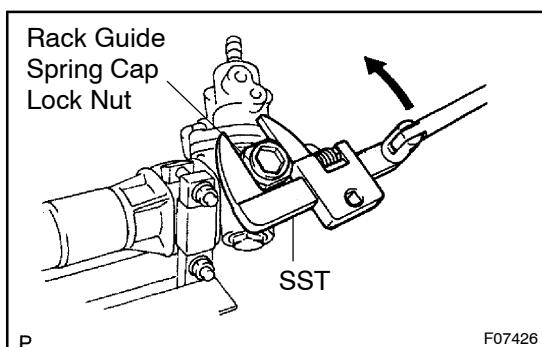
**6. REMOVE RACK GUIDE SPRING CAP LOCK NUT**

Using SST, remove the rack guide spring cap lock nut.

SST 09922-10010

NOTICE:

Use SST 09922-10010 in the direction shown in the illustration.

7. REMOVE RACK GUIDE SPRING CAP, RACK GUIDE SPRING, RACK GUIDE SUB-ASSEMBLY

- (a) Using a hexagon wrench (24 mm), remove the rack guide spring cap.
(b) Remove the rack guide spring and rack guide sub-assembly.

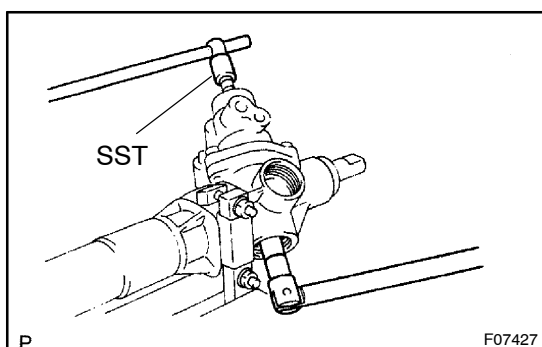
8. REMOVE RACK HOUSING CAP**9. REMOVE SELF-LOCKING NUT**

Using SST, stop the control valve shaft rotating and remove the self-locking nut.

SST 09616-00010

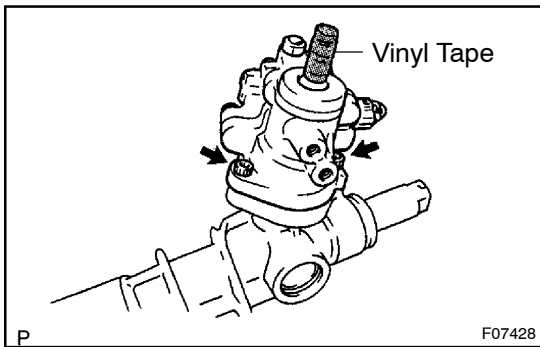
**10. REMOVE DUST COVER**

(a) Wind vinyl tape on the serrated part of the control valve shaft.

(b) Remove the dust cover.

11. REMOVE CONTROL VALVE HOUSING WITH CONTROL VALVE ASSEMBLY

(a) Using a hexagon wrench (6 mm), remove the 2 bolts.

(b) Pull out the control valve housing with control valve assembly.

(c) Remove the O-ring from the valve housing.

12. REMOVE CONTROL VALVE ASSEMBLY

(a) To prevent oil seal lip damage, wind vinyl tape on the serrated part of the control valve shaft.

(b) Using a plastic hammer, tap out the control valve assembly.

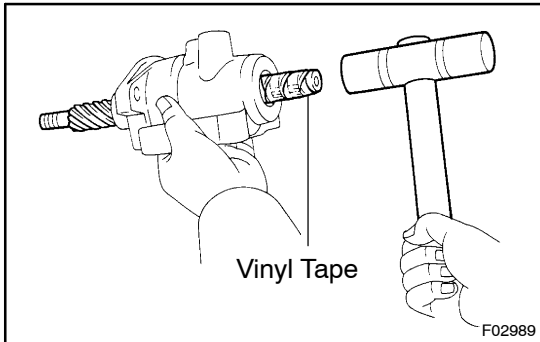
**13. REMOVE PRESSURE CONTROL VALVE**

(a) Using a hexagon wrench (6 mm), remove the 3 bolts and pressure control valve.

(b) Remove the 4 O-rings from the control valve housing.

14. REMOVE BEARING AND SPACER

Remove the bearing and spacer from the rack housing.

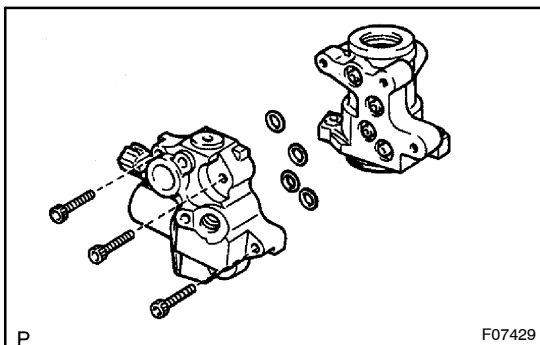
**15. REMOVE CYLINDER END STOPPER, SPACER, OIL SEAL AND STEERING RACK**

(a) Using snap ring pliers, remove the snap ring from the rack housing.

(b) Using a brass bar, press the steering rack until the cylinder end stopper slightly touches the press block.

(c) Pull out the steering rack with the cylinder end stopper, spacer and oil seal.

HINT:

If necessary, slightly tap the rack end with a brass bar and hammer.

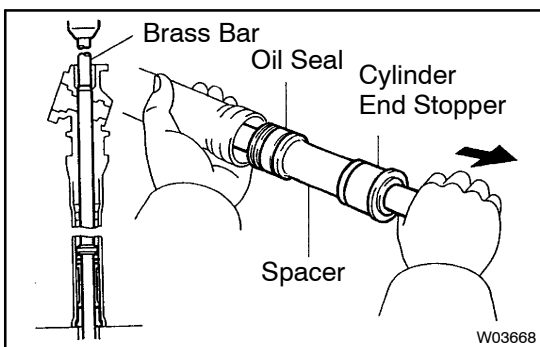

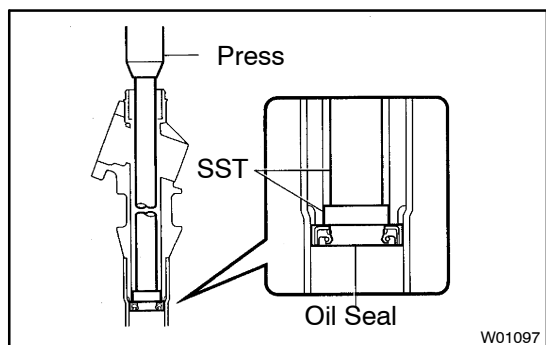
**16. REMOVE OIL SEAL**

Using SST, press out the oil seal.

SST 09950-60010 (09951-00310),
09950-70010 (09951-07360)