

DTC	21 - 24	Brake Actuator Solenoid Circuit
------------	----------------	--

CIRCUIT DESCRIPTION

This solenoid goes on when signals are received from the ECU and controls the pressure acting on the wheel cylinders thus controlling the braking force.

DTC No.	DTC Detecting Condition	Trouble Area
21	Actuator solenoid SFRR or SFRH is open or short circuit, which continues for 0.05 sec. or more.	<ul style="list-style-type: none"> • Brake Actuator • SFRR or SFRH circuit
22	Actuator solenoid SFLR or SFLH is open or short circuit, which continues for 0.05 sec. or more.	<ul style="list-style-type: none"> • Brake Actuator • SFLR or SFLH circuit
23	Actuator solenoid SRRR or SRRH is open or short circuit, which continues for 0.05 sec. or more.	<ul style="list-style-type: none"> • Brake Actuator • SRRR or SRRH circuit
24	Actuator solenoid SRLR or SRLH is open or short circuit, which continues for 0.05 sec. or more.	<ul style="list-style-type: none"> • Brake Actuator • SRLR or SRLH circuit

Fail safe function:

If any trouble occurs in the actuator solenoid circuit, the ECU cuts off current to the ABS solenoid relay and prohibits ABS control.

WIRING DIAGRAM

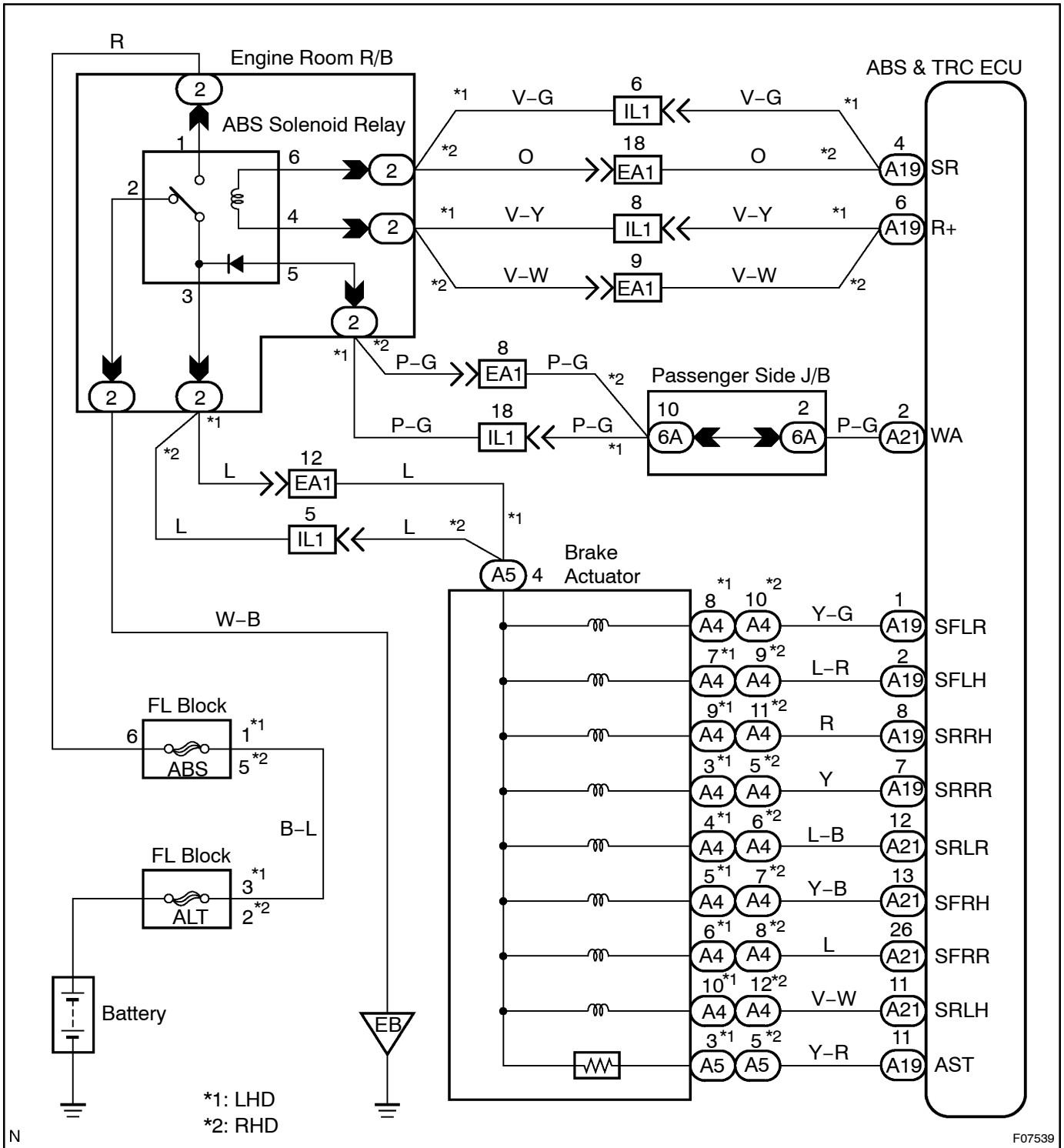

F07539

INSPECTION PROCEDURE

1 Check brake actuator solenoid.

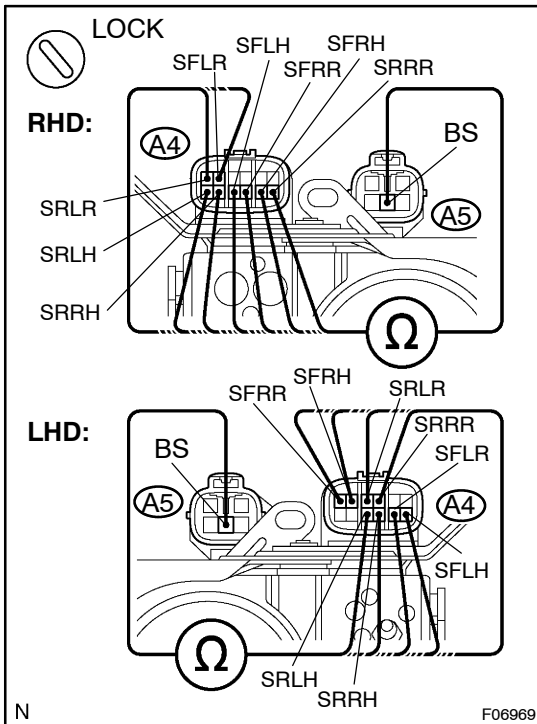
**PREPARATION:**

Disconnect the 2 connectors from brake actuator.

CHECK:

(a) RHD:

Check continuity between terminals A5 - 4 and A4 - 5, 6, 7, 8, 9, 10, 11, 12 of brake actuator.

(b) LHD:

Check continuity between terminals A5 - 4 and A4 - 3, 4, 5, 6, 7, 8, 9, 10 of brake actuator.

OK:**Continuity****HINT:**

(Reference)

Resistance of each solenoid

SFRH, SFLH, SRRH, SRLH: 3.3 - 9.3 Ω

SFRR, SFLR, SRRR, SRLR: 4.0 - 4.6 Ω

NG

Replace brake actuator.

OK

2 Check for open and short circuit in harness and connector between ABS & TRC ECU and brake actuator (See page IN-30).

NG

Repair or replace harness or connector.

OK

If the same code is still output after the DTC is deleted, check the contact condition of each connection. If the connections are normal, the ECU may be defective.