

DTC	B1178/96	Short in Rear Side Squib (LH) Circuit (to B+)
------------	-----------------	--

CIRCUIT DESCRIPTION

The rear side squib (LH) circuit consists of the airbag sensor assembly and rear side airbag assembly (LH). It causes the SRS to deploy when the SRS deployment conditions are satisfied.

For details of the function of each component, see OPERATION on page RS-3.

DTC B1178/96 is recorded when a B+ short is detected in the rear side squib (LH) circuit.

DTC No.	DTC Detecting Condition	Trouble Area
B1178/96	<ul style="list-style-type: none"> • Short circuit in side squib (LH) wire harness (to B+) • Rear side squib (LH) malfunction • Airbag sensor assembly malfunction 	<ul style="list-style-type: none"> • Rear side airbag assembly (LH) • Airbag sensor assembly • Wire harness

WIRING DIAGRAM

See page DI-355.

INSPECTION PROCEDURE

1	Prepare for inspection. (See step 1 on page DI-368)
----------	--

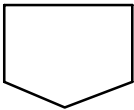

2	Check rear side squib (LH) circuit.
----------	--

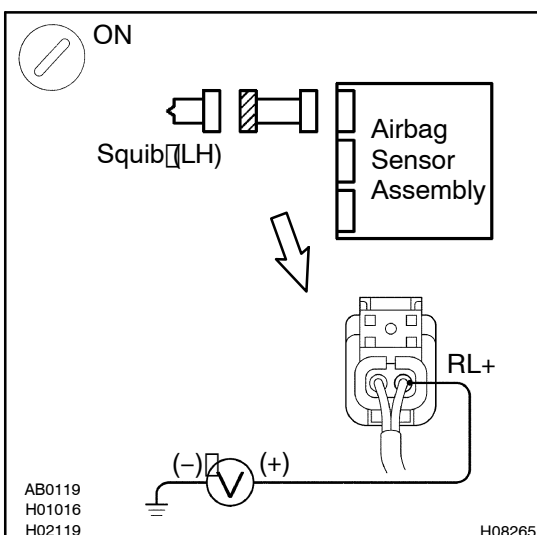

CHECK:

- Turn ignition switch to ON.
- For the connector (on the rear side airbag assembly side) between the rear side airbag assembly (LH) and the airbag sensor assembly, measure the voltage between RL+ and body ground.

OK:

Voltage: 0 V



NG Repair or replace harness or connector between rear side airbag assembly (LH) and airbag sensor assembly.



OK

3 Check airbag sensor assembly.

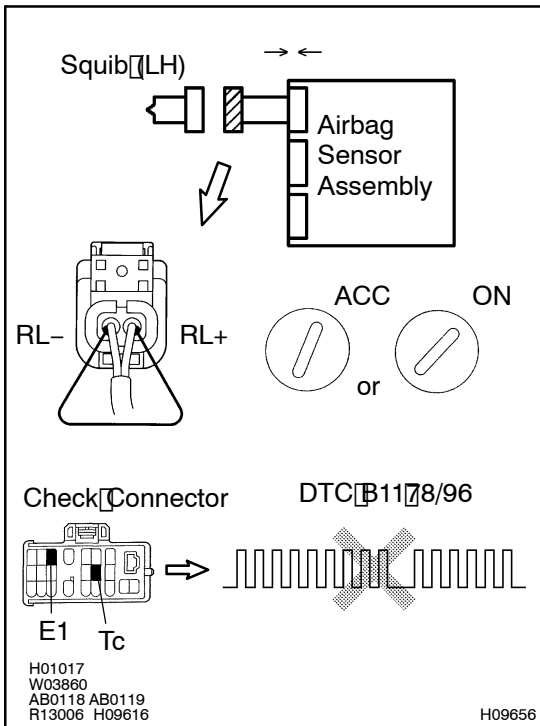

PREPARATION:

- Connect the connector to the airbag sensor assembly.
- Using a service wire, connect RL+ and RL- of the connector (on the rear side airbag assembly side) between the rear side airbag assembly (LH) and the airbag sensor assembly.
- Connect negative (-) terminal cable to the battery, and wait at least for 2 seconds.

CHECK:

- Turn ignition switch to ACC or ON and wait at least for 20 seconds.
- Clear DTC stored in memory.
(See step 5 on page DI-229)
- Turn ignition switch to LOCK, and wait at least for 20 seconds.
- Turn ignition switch to ACC or ON, and wait at least for 20 seconds.
- Check DTC. (See page DI-229)

OK:

DTC B1178/96 is not output.

HINT:

Codes other than code B1178/96 may be output at this time, but they are not relevant to this check.

NG

Replace airbag sensor assembly.

OK

4 Check rear side squib (LH).

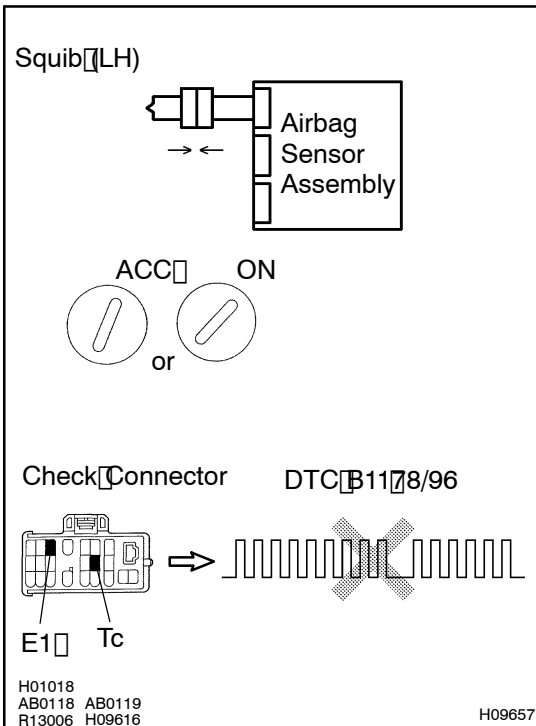

PREPARATION:

- Turn ignition switch to LOCK.
- Disconnect negative (-) terminal cable from the battery, and wait at least for 90 seconds.
- Connect the rear side airbag assembly (LH) connector.
- Connect negative (-) terminal cable to the battery, and wait at least for 2 seconds.

CHECK:

- Turn ignition switch to ACC or ON, and wait at least for 20 seconds.
- Clear DTC stored in memory.
(See step 5 on page DI-229)
- Turn ignition switch to LOCK, and wait at least for 20 seconds.
- Turn ignition switch to ACC or ON, and wait at least for 20 seconds.
- Check DTC. (See page DI-229)

OK:

DTC B1178/96 is not output.

HINT:

Codes other than code B1178/96 may be output at this time, but they are not relevant to this check.

NG

Replace rear side airbag assembly (LH).

OK

From the results of the above inspection, the malfunctioning part can now be considered normal. To make sure of this, use the simulation method to check. If the malfunctioning part can not be detected by the simulation method, replace all SRS components including the wire harness.