

VALVE BODY SPRING SPECIFICATIONS

HINT: During reassembly please refer to the spring specifications below to help you to differentiate the different springs.

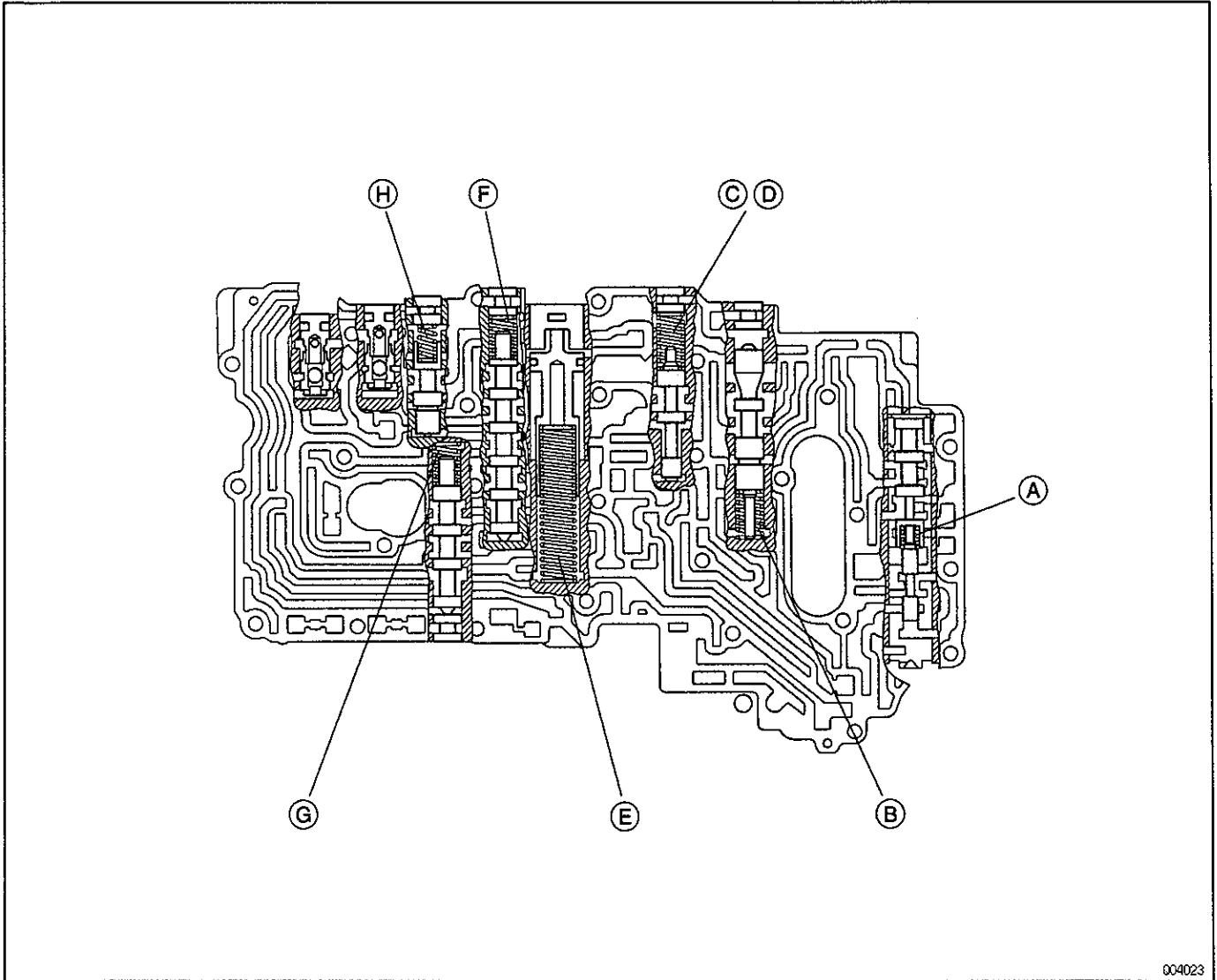

004023

Mark	Name (Color)	Free length / Outer diameter		Total No. of coils
		mm (in.)		
Ⓐ	Lock-up relay valve (Red)	23.42 (0.9220) / 5.86 (0.2307)		12.25
Ⓑ	Secondary regulator valve (Blue)	32.79(1.2909) / 9.4 (0.3700)		12.75
Ⓒ	C-1 Orifice control valve (White)	37.13 (1.4618) / 11.14 (0.4316)		11.25
Ⓓ	C-1 Orifice control valve (None)	21.50 (0.8465) / 7.76 (0.3055)		11.50
Ⓔ	C-1 Accumulator (Pink)	75.26 (2.9623) / 15.02 (0.5193)		17.06
Ⓕ	2-3 Shift valve (Purple)	30.77 (1.2114) / 9.70 (0.3819)		10.50
Ⓖ	3-4 Shift valve (Purple)	30.77 (1.2114) / 9.70 (0.3819)		10.50
Ⓗ	Reverse control valve (None)	25.58 (1.0070) / 8.64 (0.3402)		8.75