

Slide Power Seat Motor and Position Sensor Circuit

WIRING DIAGRAM

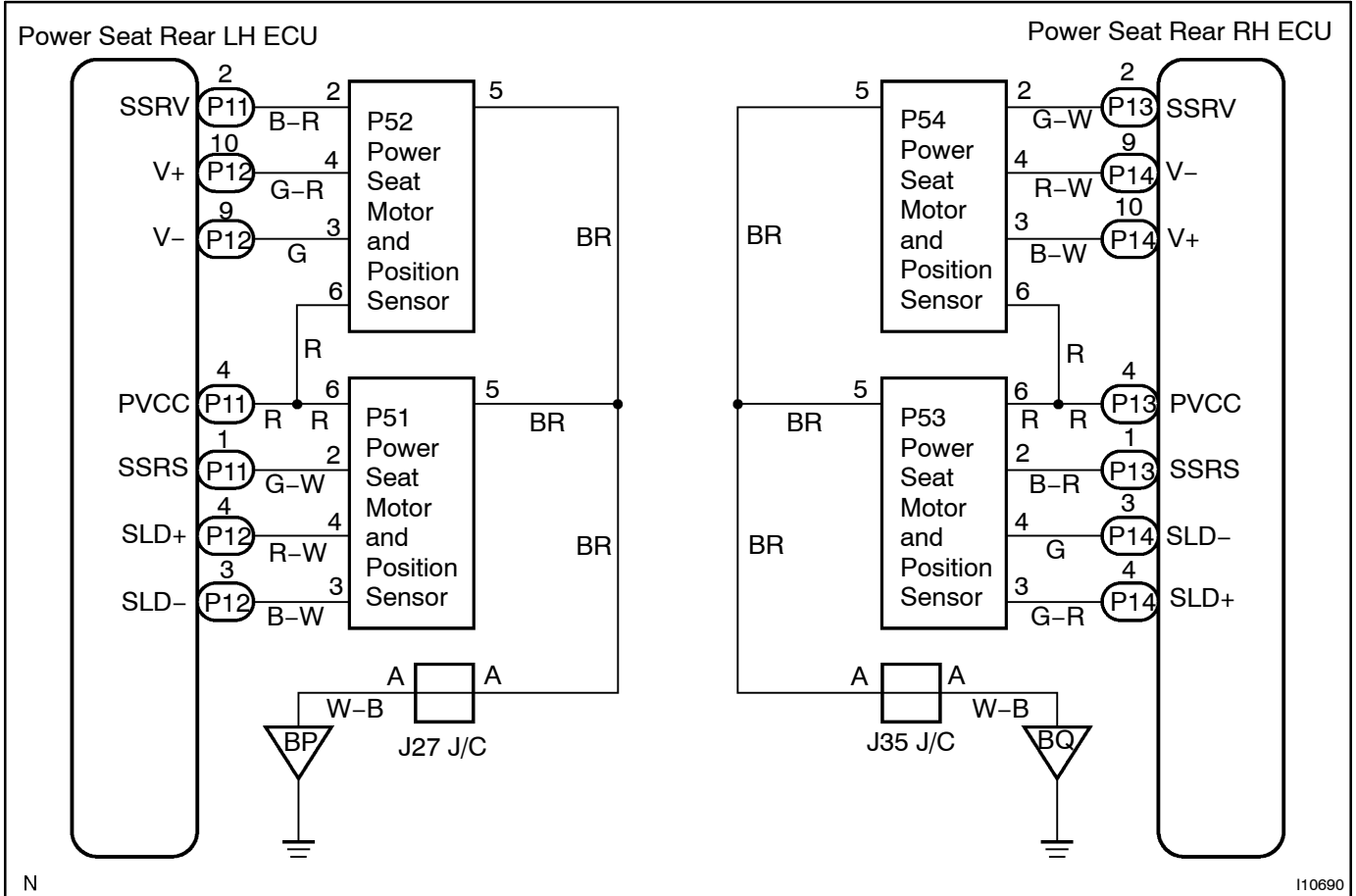

INSPECTION PROCEDURE

1 Check slide power seat motor (See page BE-121).

NG

Replace the motor.

OK

2 Check slide position sensor (See page BE-121).

NG

Replace power seat motor.

OK

3 Check harness and connectors between rear power seat ECU and slide motor and position sensors, sensors and body ground (See page IN-30).

OK

Repair or replace harness or connectors.

NG

Check and replace rear power seat ECU (See page IN-30).