

Jam protection pulse switch circuit

CIRCUIT DESCRIPTION

Jam protection pulse switch is built-in the power window motor. Pulse switch outputs ON/OFF pulse when the motor rotates.

WIRING DIAGRAM

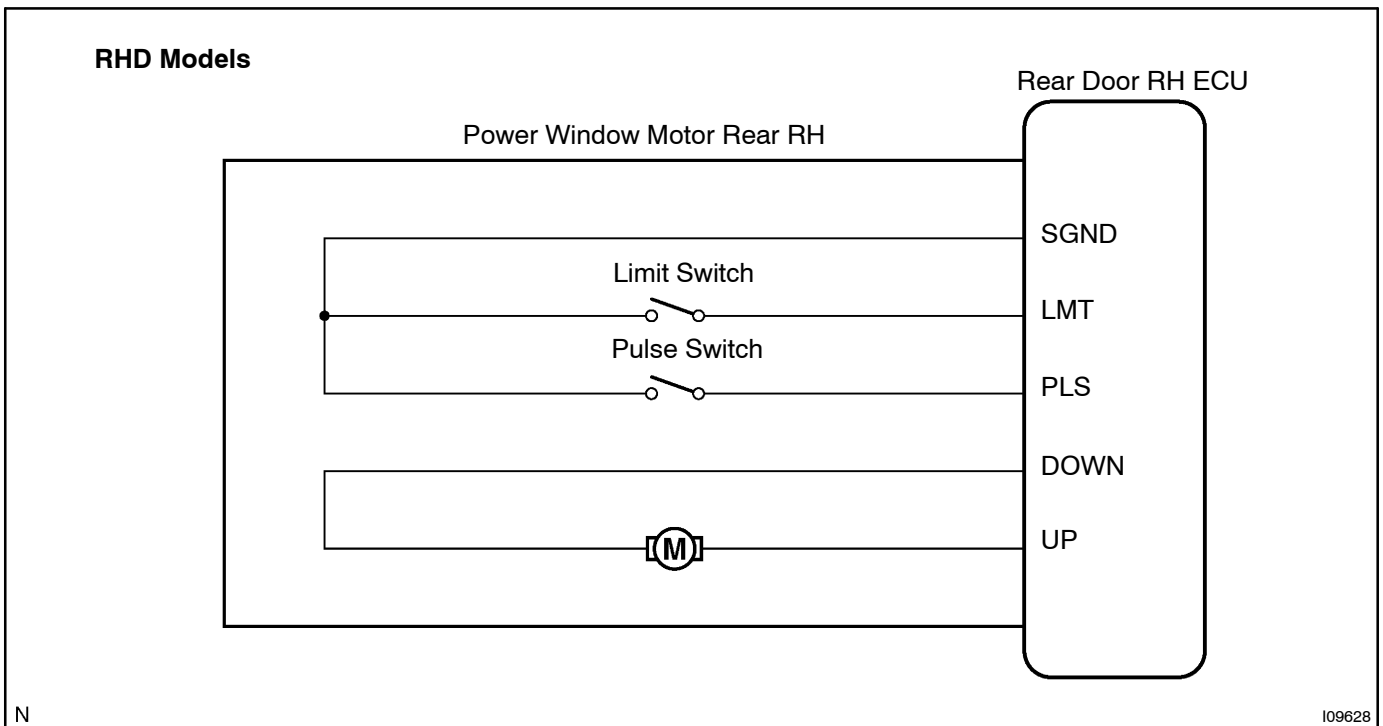
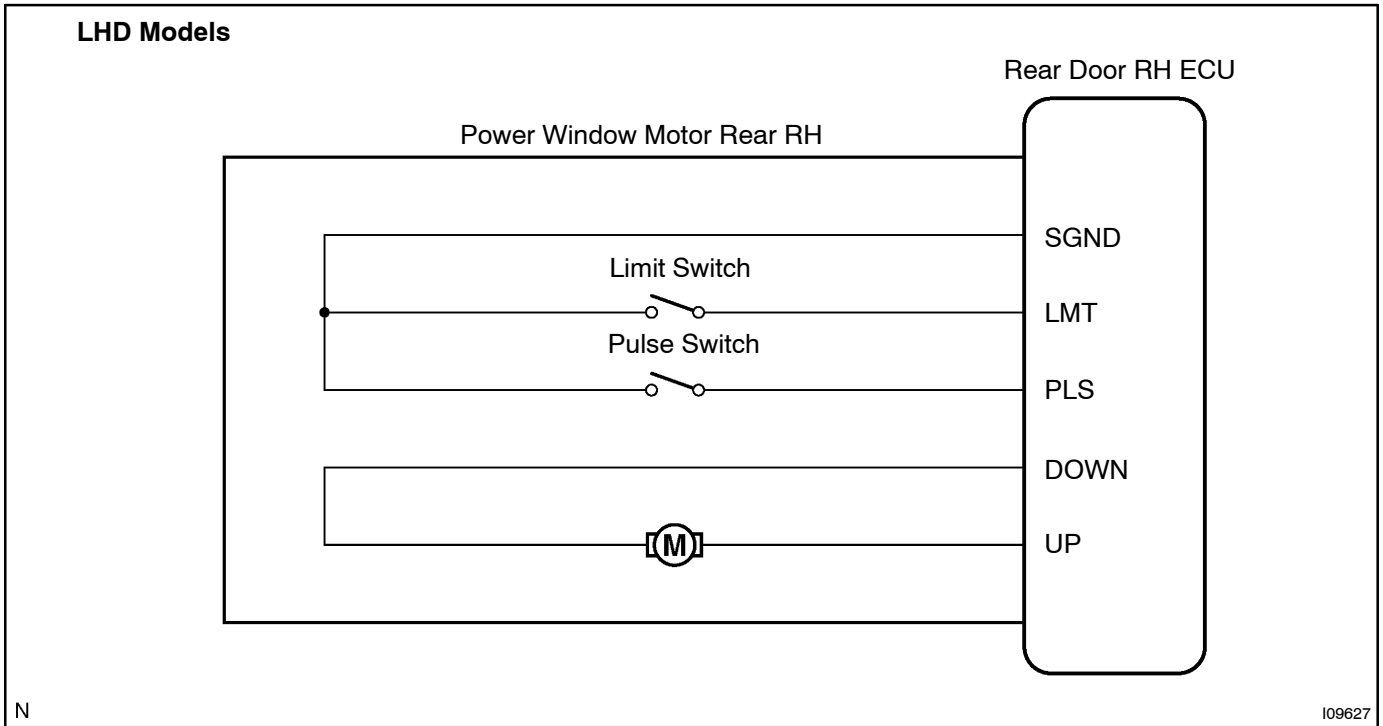

INSPECTION PROCEDURE

1 Check jam protection pulse switch (See page BE-87).

NG

Replace the power window motor.

OK

2 Check wireharness and connector between jam protection pulse switch and rear door RH ECU (See page N-30).

NG

Repair or replace wireharness or connector.

OK

Proceed to next circuit inspection shown on problems symptoms table (See page DI-639).