

INSPECTION

1. INSPECT STABILIZER BAR LINK BALL JOINT BOOT FOR DAMAGE

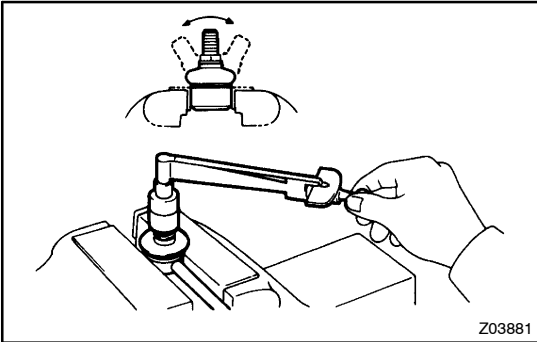

2. INSPECT STABILIZER BAR LINK BALL JOINT FOR ROTATION CONDITION

- (a) As shown in the illustration, flip the ball joint stud back and forth 5 times, before installing the nut.
- (b) Using a torque wrench, turn the nut continuously 1 turn per 2 – 4 seconds and take the torque reading on the 5th turn.

Turning torque:

0.05 – 1.5 N·m (0.5 – 15 kgf·cm, 0.4 – 13 in.·lbf)