

## REASSEMBLY

### NOTICE:

When using a vise, do not overtighten it.

1. COAT PARTS INDICATED BY ARROWS WITH POWER STEERING FLUID OR MOLYBDENUM DISULFIDE LITHIUM BASE GREASE (See page SR-32)

2. INSTALL OIL SEAL

- (a) Coat a new oil seal lip with power steering fluid.
- (b) Using SST, press in the oil seal.

SST 09950-60010 (09951-00240, 09951-00430, 09952-06010), 09950-70010 (09951-07360)

### NOTICE:

- Make sure that the oil seal is installed facing in the correct direction.
- Take care that the oil seal does not get reversed as you install it.

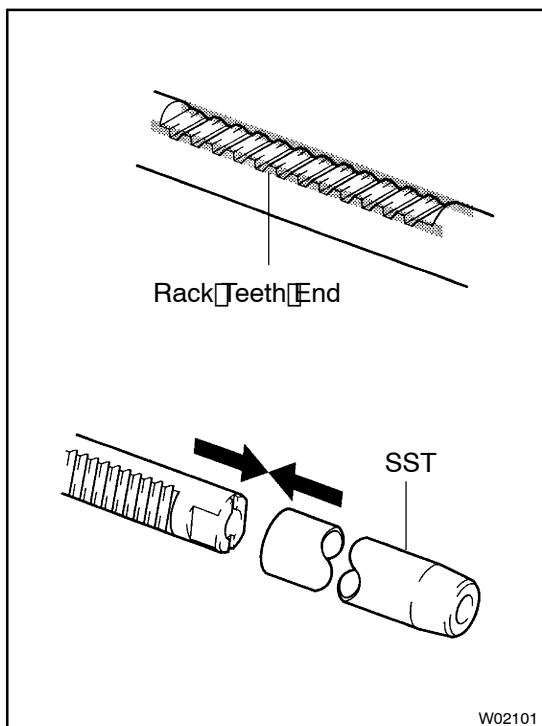

3. INSTALL STEERING RACK

- (a) Install SST to the steering rack.  
SST 09631-20102

### HINT:

If necessary, scrape the burrs off the rack teeth end and burr-nish.

- (b) Coat SST with power steering fluid.
- (c) Install the steering rack into the rack housing.

### NOTICE:

Be careful not to damage the oil seal lip.

- (d) Remove the SST.  
SST 09631-20102

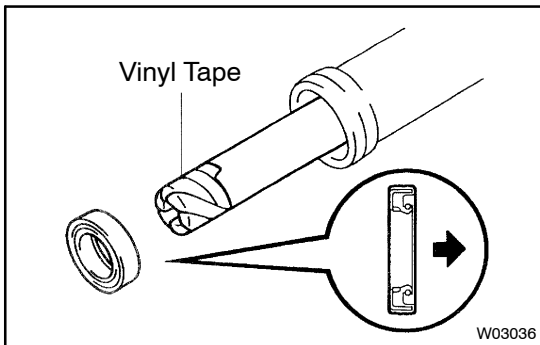

#### 4. INSTALL OIL SEAL AND SPACER

- (a) Coat a new oil seal lip with power steering fluid.
- (b) To prevent oil seal lip damage, wind vinyl tape on the steering rack end, and apply power steering fluid.
- (c) Install the oil seal by pushing it into the rack housing without tilting.

#### NOTICE:

- **Make sure that the oil seal is installed facing in the correct direction.**
  - **Be careful not to damage the oil seal lip.**
- (d) Install the spacer.

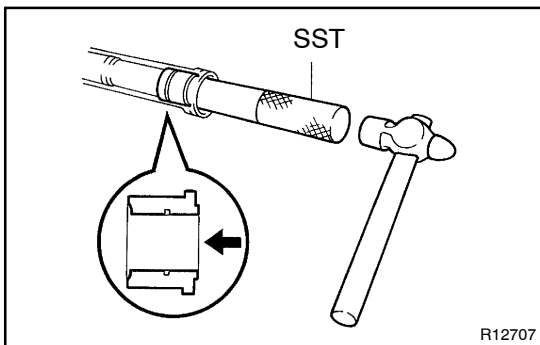

#### 5. INSTALL CYLINDER END STOPPER

- (a) Using SST and a hammer, drive in the cylinder end stopper.  
SST 09612-22011
- (b) Using snap ring pliers, install the snap ring.

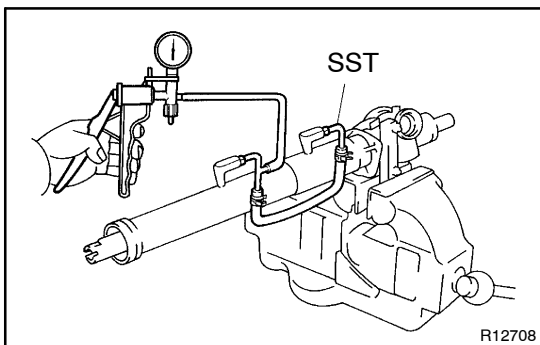

#### 6. AIR TIGHTNESS TEST

- (a) Install SST to the rack housing.  
SST 09631-12071
  - (b) Apply 53 kPa (400 mmHg, 15.75 in.Hg) of vacuum for about 30 seconds.
  - (c) Check that there is no change in the vacuum.
- If there is change in the vacuum, check the installation of the oil seals.

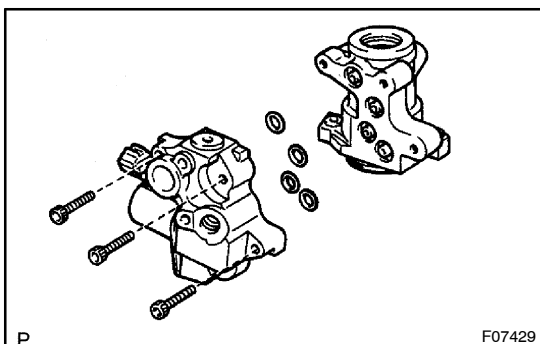

#### 7. INSTALL PRESSURE CONTROL VALVE

- (a) Coat 4 new O-rings with power steering fluid and install them to the control valve housing.
- (b) Using hexagon wrench (6 mm), install the pressure control valve with the 3 bolts.

**Torque: 18 N·m (185 kgf·cm, 13 ft·lbf)**

**8. INSTALL CONTROL VALVE ASSEMBLY**

- (a) Coat the teflon rings of the control valve assembly with power steering fluid.
- (b) To prevent oil seal lip damage, wind vinyl tape on the serrated part of the control valve shaft.
- (c) Install the control valve assembly into the control valve housing.

**NOTICE:**

**Be careful not to damage the teflon rings and oil seal.**

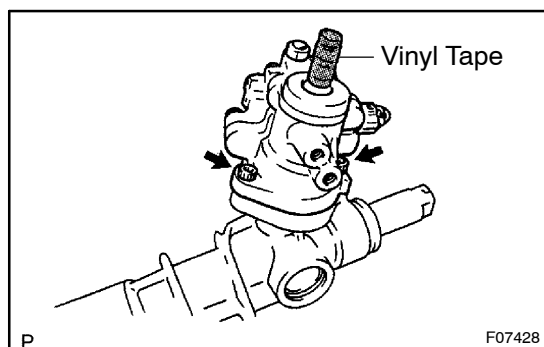
**9. INSTALL CONTROL VALVE HOUSING**

- (a) Coat a new O-ring with power steering fluid and install it to the control valve housing.
- (b) Using a hexagon wrench (6 mm), install the control valve housing with the 2 bolts.

**Torque: 18 N·m (185 kgf·cm, 13 ft·lbf)**

**10. INSTALL DUST COVER****11. INSTALL BEARING AND SPACER**

Install the spacer and a new bearing to the rack housing.

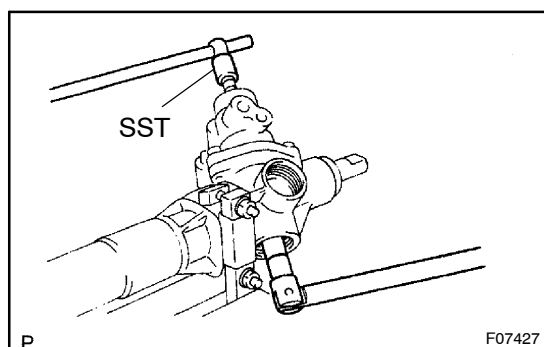
**12. INSTALL SELF-LOCKING NUT**

Using SST, stop the control valve shaft rotating and install a new self-locking nut.

SST 09616-00010

**Torque: 39 N·m (400 kgf·cm, 29 ft·lbf)**

**13. INSTALL RACK HOUSING CAP**

- (a) Apply sealant to 2 or 3 threads of the rack housing cap.

**Sealant:**

**Part No. 08833-00080, THREE BOND 1344, LOCTITE 242 or equivalent**

- (b) Install the rack housing cap.

**Torque: 69 N·m (700 kgf·cm, 51 ft·lbf)**

**14. INSTALL RACK GUIDE SUB-ASSEMBLY, RACK GUIDE SPRING AND RACK GUIDE SPRING CAP**

- (a) Install the rack guide sub-assembly and rack guide spring.
- (b) Apply sealant to 2 or 3 threads of the rack guide spring cap.

**Sealant:**

**Part No. 08833-00080, THREE BOND 1344, LOCTITE 242 or equivalent**

- (c) Temporarily install the rack guide spring cap.

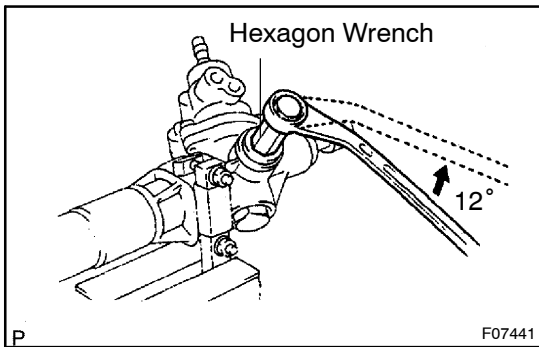

**15. ADJUST TOTAL PRELOAD**

- (a) To prevent the steering rack teeth from damaging the oil seal lip, temporarily install the RH and LH rack ends.
- (b) Using a hexagon wrench (24 mm), torque the rack guide spring cap.

**Torque: 25 N·m (250 kgf·cm, 18 ft·lbf)**

- (c) Using a hexagon wrench (24 mm), return the rack guide spring cap 12°.

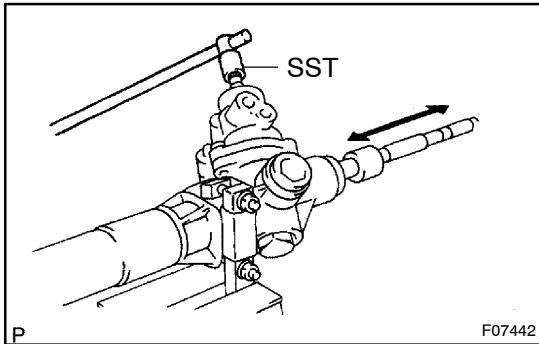

- (d) Using SST, turn the control valve shaft right and left 1 or 2 times.

SST 09616-00010

- (e) Using a hexagon wrench (24 mm), loosen the rack guide spring cap until the rack guide spring is not functioning.

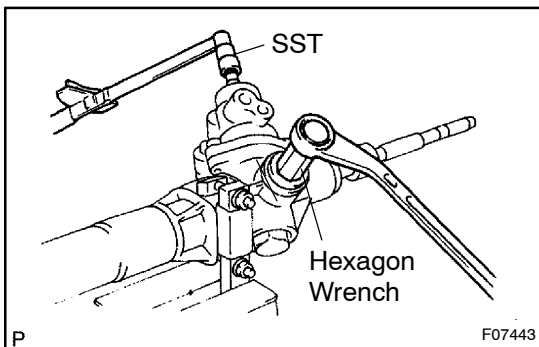

- (f) Using SST, a torque wrench and hexagon wrench (24 mm), tighten the rack guide spring cap until the preload is within specification.

SST 09616-00010

**Preload (turning):**

**0.6 - 2.0 N·m (6 - 20 kgf·cm, 5.2 - 17.4 in·lbf)**

**16. INSTALL RACK GUIDE SPRING CAP LOCK NUT**

- (a) Apply sealant to 2 or 3 threads of the rack guide spring cap lock nut.

**Sealant:**

**Part No. 08833-00080, THREE BOND 1344, LOCTITE 242 or equivalent**

- (b) Temporarily install the rack guide spring cap lock nut.

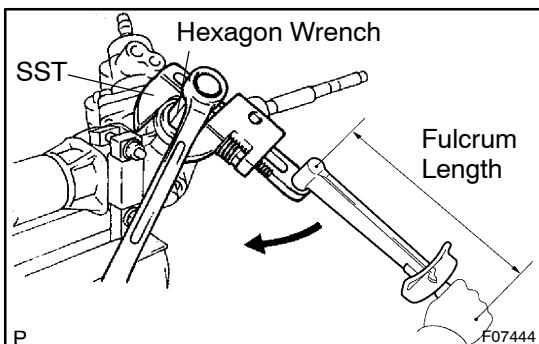

- (c) Using a hexagon wrench (24 mm), hold the rack guide spring cap and using SST, torque the rack guide spring cap lock nut.

SST 09922-10010

**Torque: 50 N·m (513 kgf·cm, 37 ft·lbf)**

**NOTICE:**

**Use SST 09922-10010 in the direction shown in the illustration.**

**HINT:**

Use a torque wrench with a fulcrum length of 345 mm (13.58 in.).

- (d) Recheck the total preload.

**Preload (turning):**

**0.6 – 2.0 N·m (6 – 20 kgf·cm, 5.2 – 17.4 in.·lbf)**

- (e) Remove the RH and LH rack ends.

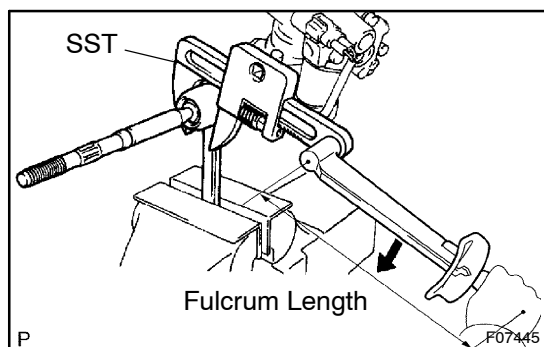
**17. INSTALL RH AND LH CLAW WASHERS AND RACK ENDS**

- (a) Install a new claw washer, and temporarily install the rack end.

**HINT:**

Align the claws of the washer with the steering rack grooves.

- (b) Using a wrench, hold the steering rack steadily and using SST, torque the rack end.

SST 09922-10010

**Torque: 77 N·m (782 kgf·cm, 57 ft·lbf)**

**NOTICE:**

**Use SST 09922-10010 in the direction shown in the illustration.**

**HINT:**

Use a torque wrench with a fulcrum length of 380 mm (14.96 in.).

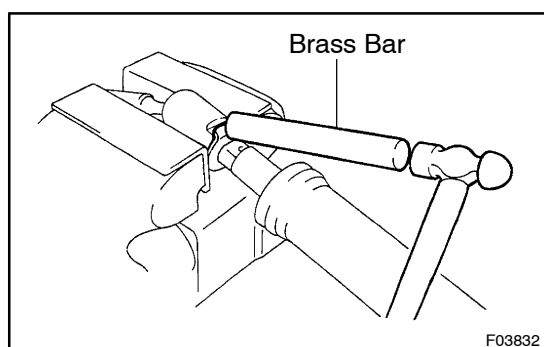

- (c) Using a brass bar and hammer, stake the washer.

**NOTICE:**

**Avoid any impact on the steering rack.**

- (d) Employ the same manner described above to the other side.

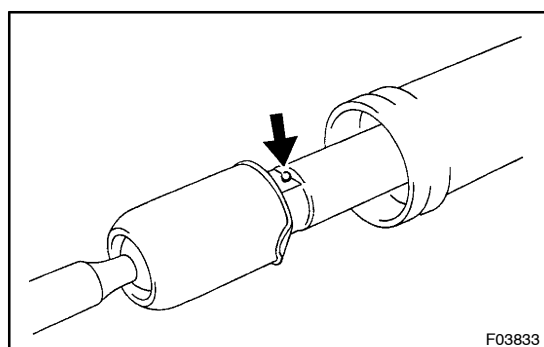
**18. INSTALL RH AND LH RACK BOOTS, CLAMPS AND CLIPS**

- (a) Ensure that the steering rack hole is not clogged with grease.

**HINT:**

If the hole is clogged, the pressure inside the boot will change after it is assembled and the steering wheel is turned.

- (b) Install the boot, clip, clamp and screw.

**NOTICE:**

**Be careful not to damage or twist the boot.**

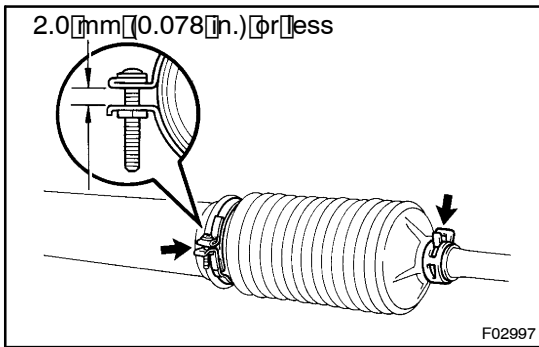

- (c) Tighten the clamp with the screw as shown in the illustration.
- (d) Employ the same manner described above to the other side.

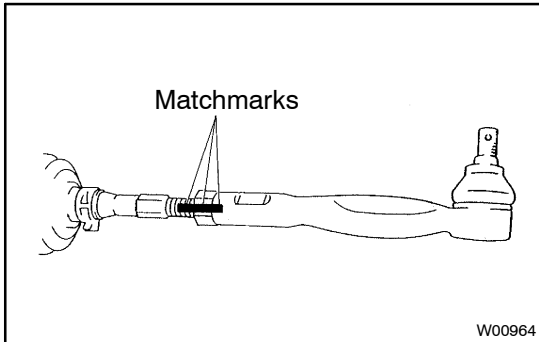

**19. INSTALL RH AND LH TIE ROD ENDS AND LOCK NUTS**

- (a) Screw the lock nut and tie rod end onto the track end until the matchmarks are aligned.
- (b) After adjusting toe-in, torque the nut  
(See page SA-5)
- Torque: 56 N·m (570 kgf·cm, 41 ft·lbf)**
- (c) Employ the same manner described above to the other side.

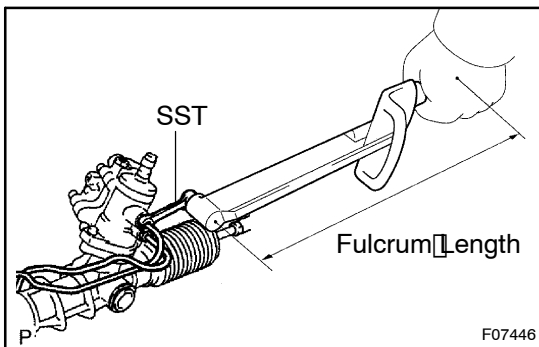

**20. INSTALL 2 TURN PRESSURE TUBES**

- (a) Using SST, install the 2 turn pressure tubes.  
SST 09633-00020  
**Torque: 20 N·m (203 kgf·cm, 15 ft·lbf)**

**HINT:**

- Use a torque wrench with a fulcrum length of 300 mm (11.81 in.).
- This torque value is effective in case that SST is parallel to a torque wrench.
- (b) Install the tube clamp.