

<b>DTC</b>	<b>B0130/63</b>	<b>Short in P/T Squib (RH) Circuit</b>
------------	-----------------	--

## CIRCUIT DESCRIPTION

The P/T squib (RH) circuit consists of the airbag sensor assembly and seat belt pretensioner (RH). It causes the SRS to deploy when the SRS deployment conditions are satisfied.

For details of the function of each component, see OPERATION on page RS-3.

DTC B0130/63 is recorded when a short is detected in the P/T squib (RH) circuit.

DTC No.	DTC Detecting Condition	Trouble Area
B0130/63	<ul style="list-style-type: none"> <li>• Short circuit between PR+ wire harness and PR- wire harness of squib</li> <li>• P/T squib (RH) malfunction</li> <li>• Airbag sensor assembly malfunction</li> </ul>	<ul style="list-style-type: none"> <li>• Seat belt pretensioner (RH)</li> <li>• Airbag sensor assembly</li> <li>• Wire harness</li> </ul>

## WIRING DIAGRAM

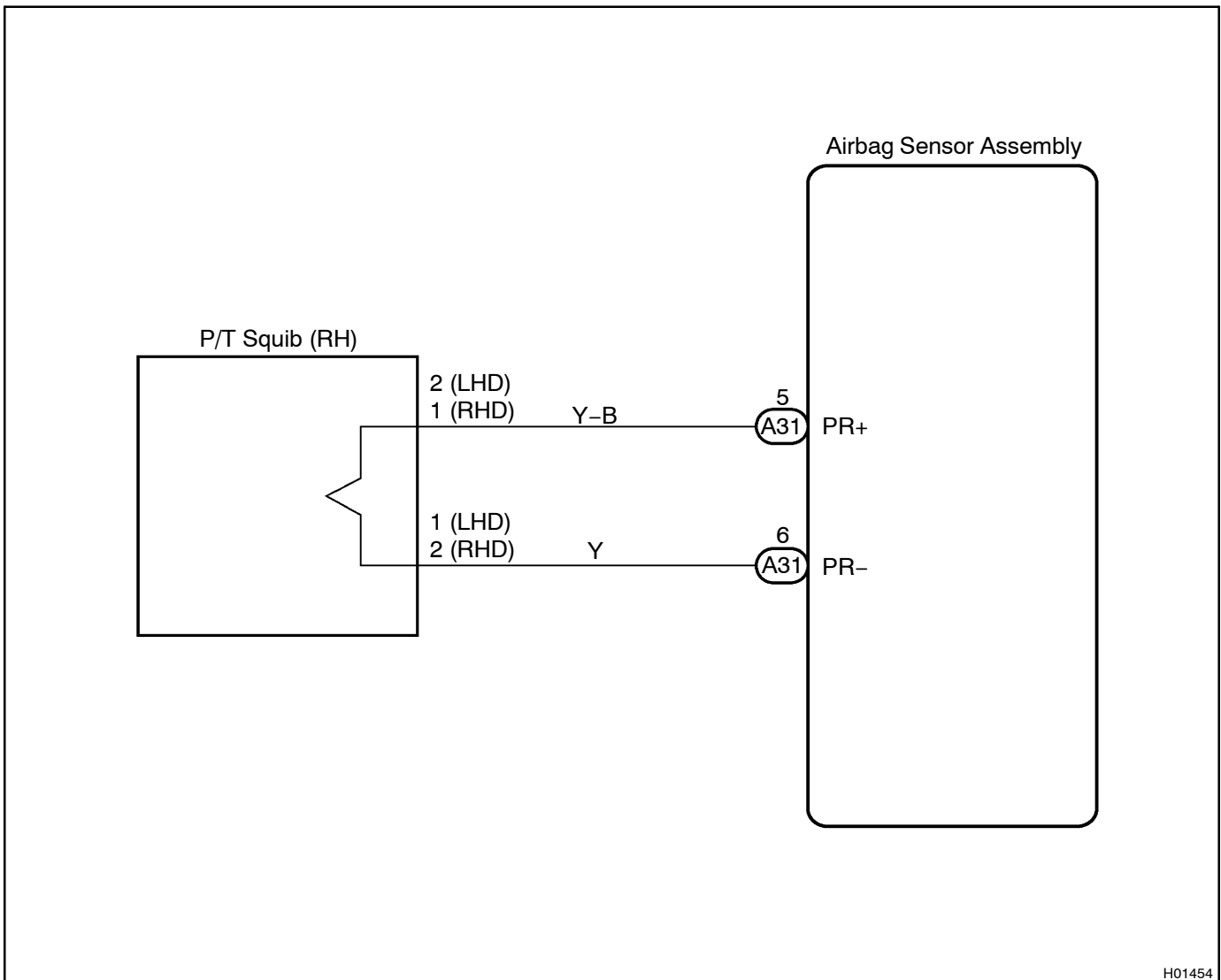

## INSPECTION PROCEDURE

1 Prepare for inspection. (See step 1 on page DI-368)

2 Check P/T squib (RH) circuit.

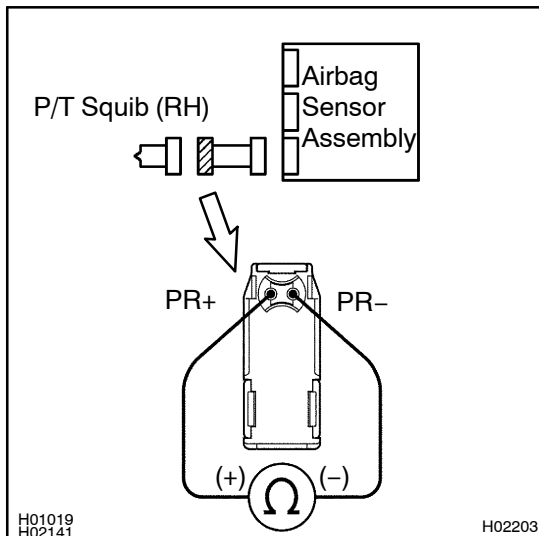
**PREPARATION:**

Release the airbag activation prevention mechanism of the connector (on the airbag sensor assembly side) between the airbag sensor assembly and the seat belt pretensioner (RH). (See page DI-229)

**CHECK:**

For the connector (on the seat belt pretensioner side) between the seat belt pretensioner (RH) and the airbag sensor assembly, measure the resistance between PR+ and PR-.

**OK:**

**Resistance: 1 MΩ or Higher**

NG

Repair or replace harness or connector between seat belt pretensioner (RH) and airbag sensor assembly.

OK

### 3 Check airbag sensor assembly.

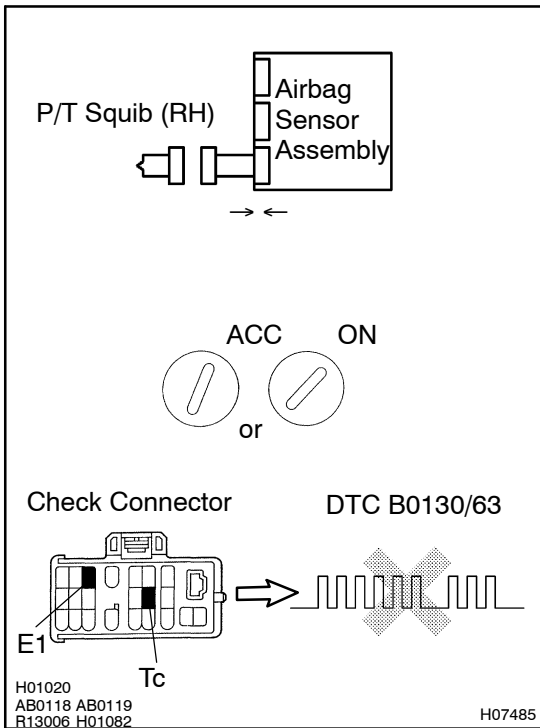

#### PREPARATION:

- Connect the connector to the airbag sensor assembly.
- Connect negative (-) terminal cable to the battery, and wait at least for 2 seconds.

#### CHECK:

- Turn ignition switch to ACC or ON and wait at least for 20 seconds.
- Clear DTC stored in memory. (See page DI-229)
- Turn ignition switch to LOCK, and wait at least for 20 seconds.
- Turn ignition switch to ACC or ON, and wait at least for 20 seconds.
- Check DTC. (See page DI-229)

#### OK:

**DTC B0130/63 is not output.**

#### HINT:

Codes other than code B0130/63 may be output at this time, but they are not relevant to this check.

**NG**

**Replace airbag sensor assembly.**

**OK**

#### 4 Check P/T squib (RH).

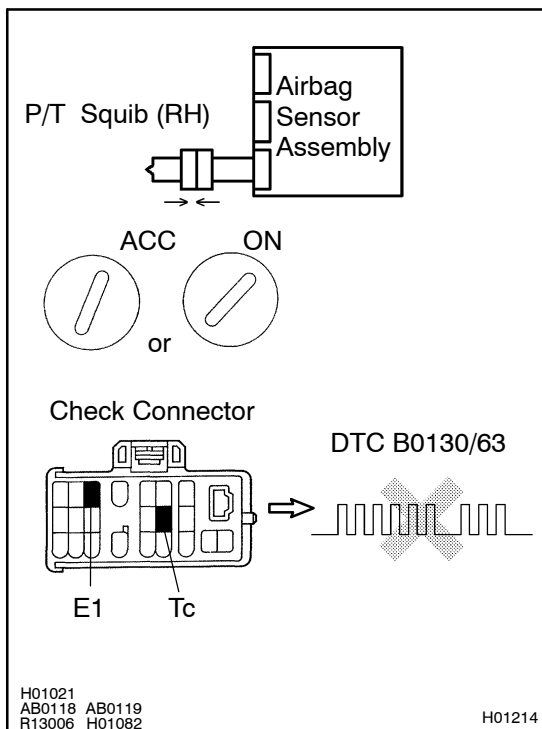

#### PREPARATION:

- Turn ignition switch to LOCK.
- Disconnect negative (-) terminal cable from the battery, and wait at least for 90 seconds.
- Connect the seat belt pretensioner (RH) connector.
- Connect negative (-) terminal cable to the battery, and wait at least for 2 seconds.

#### CHECK:

- Turn ignition switch to LOCK, and wait at least for 20 seconds.
- Turn ignition switch to ACC or ON, and wait at least for 20 seconds.
- Clear DTC stored in memory. (See page DI-229)
- Turn ignition switch to LOCK, and wait at least for 20 seconds.
- Turn ignition switch to ACC or ON, and wait at least for 20 seconds.
- Check DTC. (See page DI-229)

#### OK:

**DTC B0130/63 is not output.**

#### HINT:

Codes other than code B0130/63 may be output at this time, but they are not relevant to this check.

**NG**

**Replace seat belt pretensioner (RH).**

**OK**

**From the results of the above inspection, the malfunctioning part can now be considered normal. To make sure of this, use the simulation method to check.**