

AUTOMATIC TRANSMISSION

- ❶ For the transmission, the A342E automatic transmission that excels in handling in all ranges has been adopted. This transmission ensures both smooth shifting characteristics and dynamic performance through the concurrent use of the ETCS-i (Electronic Throttle Control System - intelligent).
- ❷ A gate type shift lever has been adopted. It enables the driver to shift the gears through a simple movement of the shift lever.

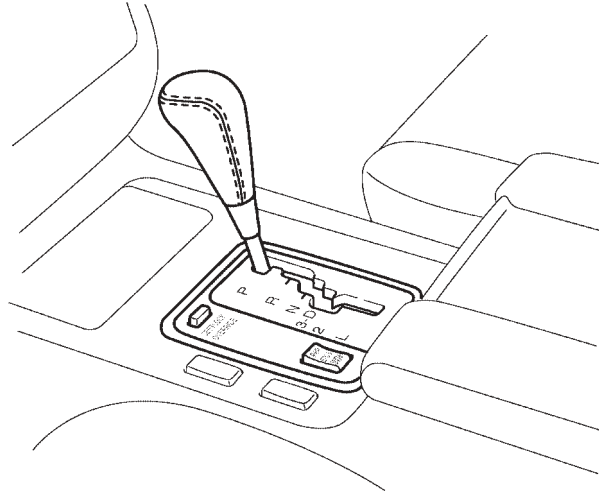

162MO14

MO

SUSPENSION

- ❶ A double-wishbone suspension system has been adopted for both the front and rear suspensions, and an electronically modulated air suspension is provided as standard equipment on all models. Thus, a flat vehicle posture is realized, while ensuring soft riding comfort.
- ❷ The suspension components have been finely tuned to achieve excellent maneuverability, stability, and riding comfort.

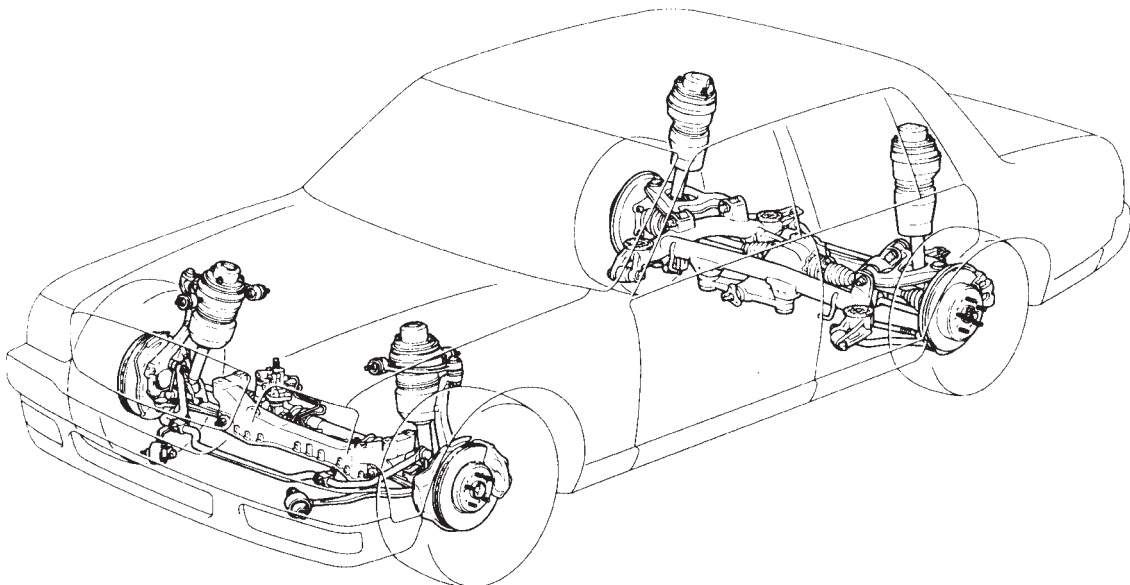

162MO27