

# Stop Light Switch Signal Circuit

## CIRCUIT DESCRIPTION

The purpose of this circuit is to prevent the engine from stalling, while driving in lock-up condition, when brakes are suddenly applied.

When the brake pedal is depressed, this switch sends a signal to Engine and ECT ECU. Then the Engine and ECT ECU cancels operation of the lock-up clutch while braking is in progress.

## WIRING DIAGRAM

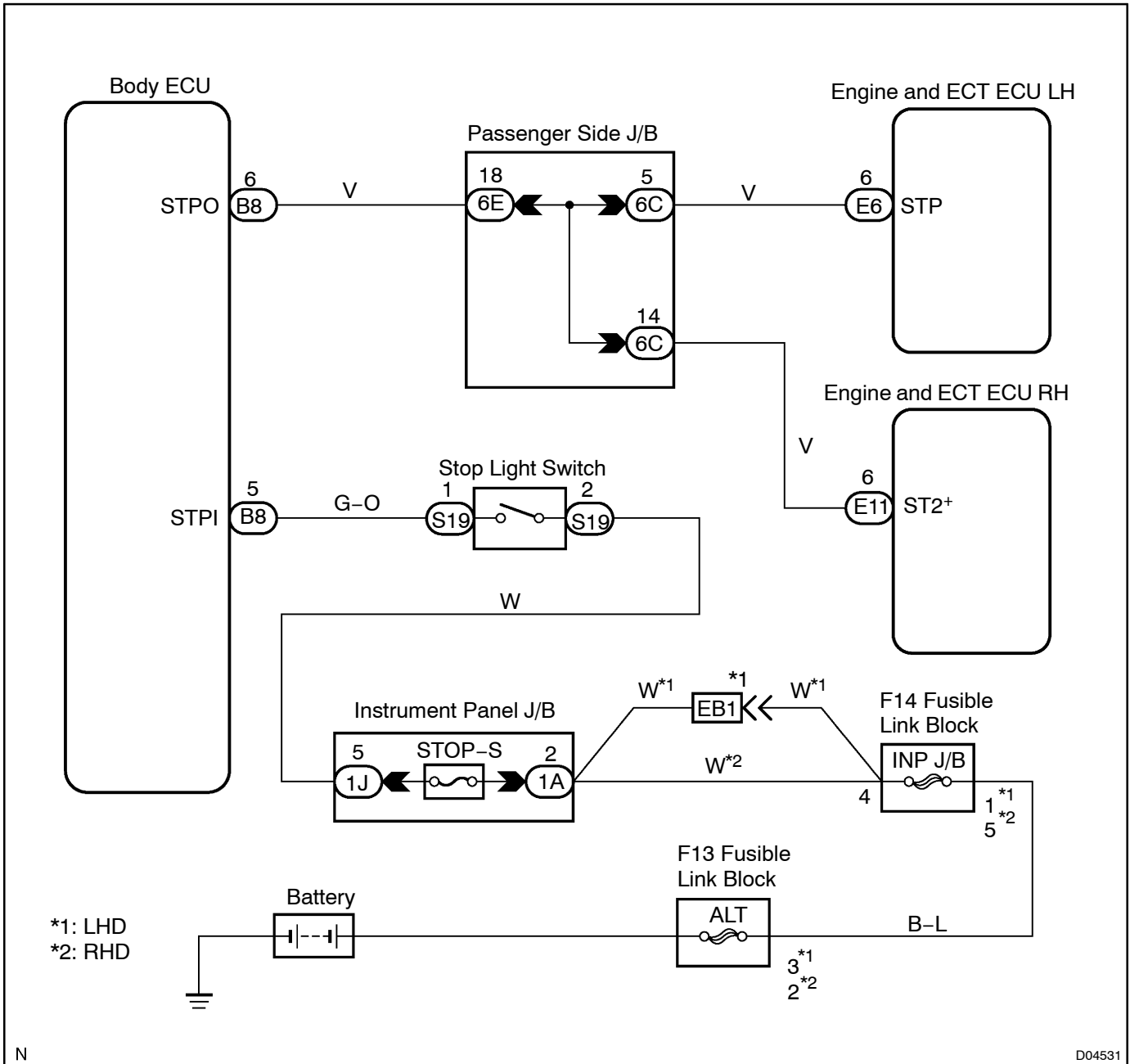

# INSPECTION PROCEDURE

## HINT:

Read freeze frame data using hand-held tester. Because freeze frame records the engine conditions when the malfunction is detected, when troubleshooting it is useful for determining whether the vehicle was running or stopped, the engine warmed up or not, the air-fuel ratio lean or rich, etc. at the time of the malfunction.

<b>1</b>	<b>Check operation of stop light.</b>
----------	---------------------------------------

## CHECK:

Check if the stop lights go on and off normally when the brake pedal is depressed and released.

<b>NG</b>	<b>Check and repair stop light circuit (See page BE-46).</b>
-----------	--

<b>OK</b>
-----------

<b>2</b>	<b>Check STP signal.</b>
----------	--------------------------

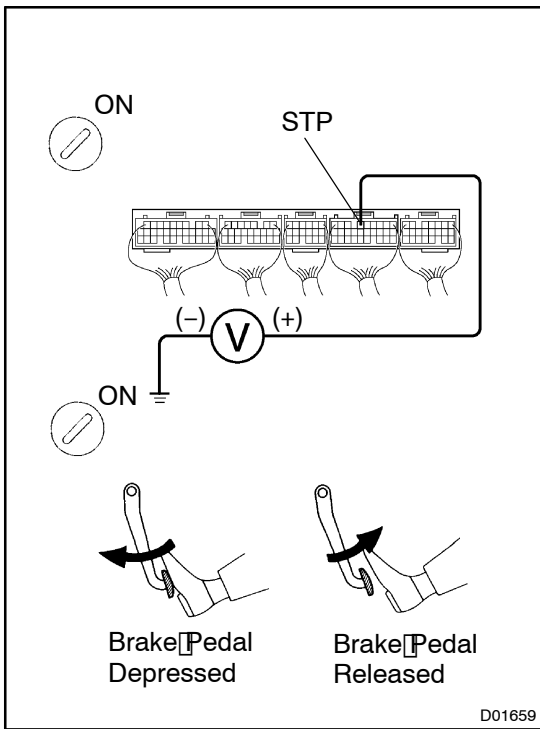

### When using hand-held tester:

#### PREPARATION:

- (a) Connect the hand-held tester to the DLC3.
- (b) Turn the ignition switch ON and hand-held tester main switch ON.

#### CHECK:

Read the STP signal on the hand-held tester.

#### OK:

**Brake pedal is depressed: STP..ON**  
**Brake pedal is released: STP..OFF**

### When not using hand-held tester:

#### PREPARATION:

- (a) Remove the glove compartment door.
- (b) Turn the ignition switch ON.

#### CHECK:

Check voltage between terminal STP of the Engine and ECT ECU and body ground.

#### OK:

Brake pedal	Voltage
Depressed	7.5 - 4V
Released	Below .5V

<b>OK</b>	<b>Proceed to next circuit inspection shown in problem symptoms table (See page DI-19).</b>
-----------	---

<b>NG</b>
-----------

3 Check harness and connector between Engine and ECT ECU and Body ECU (See page IN-30).

NG

Repair or replace harness or connector.

OK

Check and replace Engine and ECT ECU (See page IN-30).