

<b>DTC</b>	<b>35</b>	<b>Cool Air Bypass Damper Position Sensor Circuit (Passenger Side)</b>
------------	-----------	--

**CIRCUIT DESCRIPTION**

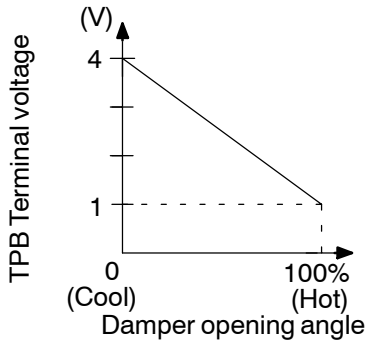

This sensor detects the position of the cool air bypass damper and sends the appropriate signals to the A/C control assembly. The position sensor is built into the cool air bypass damper control servomotor assembly.

DTC No.	Detection Item	Trouble Area
35	Short to ground or power source circuit in cool air bypass damper position sensor circuit.	<ul style="list-style-type: none"> <li>Cool air bypass damper position sensor.</li> <li>Harness or connector between cool air bypass damper control servomotor assembly and A/C control assembly.</li> <li>A/C control assembly.</li> </ul>

**WIRING DIAGRAM**

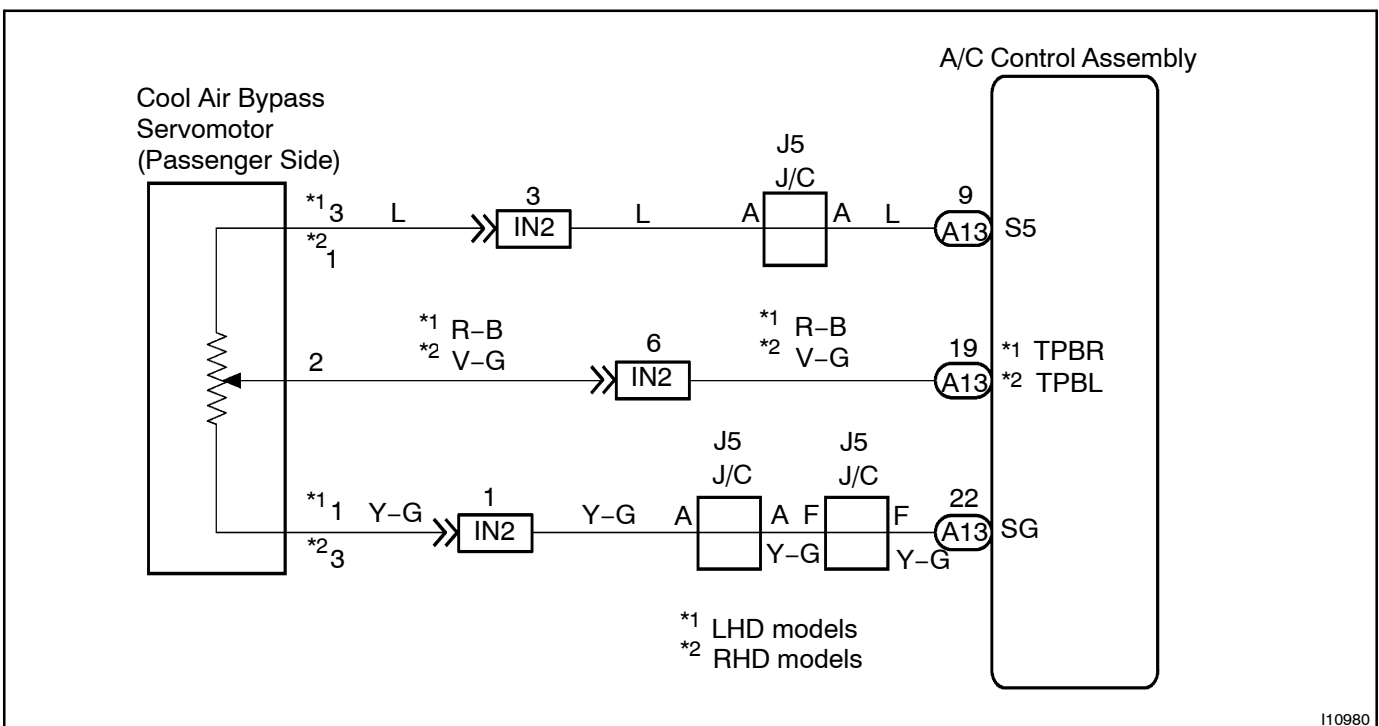

## INSPECTION PROCEDURE

- 1 Check voltage between terminals TPBR (RHD: TPBL) and SG of A/C control assembly connector.

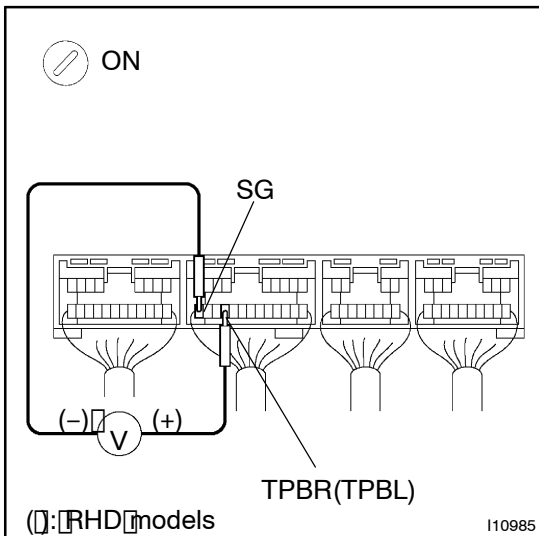
**PREPARATION:**

Remove A/C control assembly with connectors still connected.

**CHECK:**

- Turn ignition switch to ON.
- Change the set temperature to activate the cool air bypass damper control servomotor, and measure voltage between terminals TPBR (TPBL) and SG of A/C control assembly each time when the set temperature is changed.

( ) : RHD models

**OK:**

Set Temperature	Voltage
Max. cool	3.5 - 4.5V
Max. hot	0.5 - 1.8V

**HINT:**

As the set temperature increases, the voltage decreases.

NG

Go to step 2.

OK

Proceed to next circuit inspection shown on problem symptoms table (See page DI-780). However, if DTC 35 is displayed, check and replace A/C control assembly.

## 2 Check cool air bypass damper position sensor.

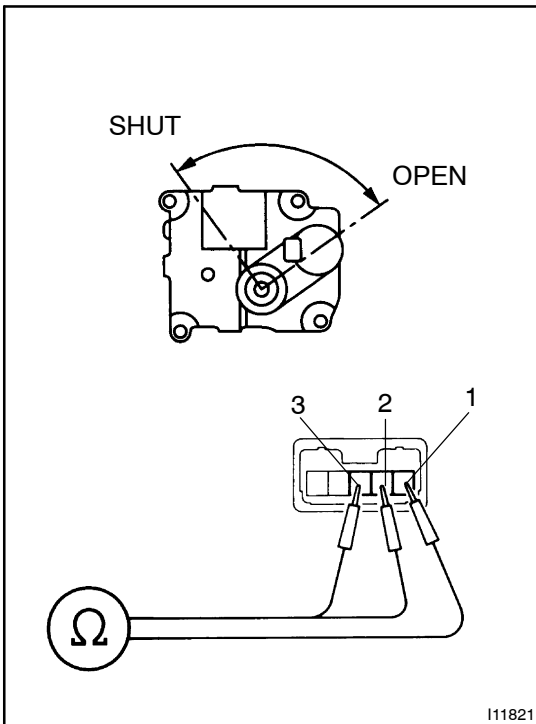

### PREPARATION:

Remove cool air bypass damper control servomotor (See page AC-89).

### CHECK:

Measure resistance between terminals 1 and 3 of cool air bypass damper control servomotor assembly connector.

### OK:

Resistance: 4.2 - 7.2 kΩ

### CHECK:

While operating cool air bypass damper control servomotor, following the procedure on page DI-822, measure resistance between terminals 1 and 2 (3) of cool air bypass damper control servomotor assembly connector.

( ): RHD models

### OK:

Damper Position	Resistance
Max. Cool	3.76 - 5.76 kΩ
Max. Hot	0.94 - 1.44 kΩ

### HINT:

As the cool air bypass damper control servomotor moves from the cool side to the hot side, the resistance decreases.

NG

Replace cool air bypass damper control servomotor assembly.

OK

## 3 Check harness and connector between A/C control assembly and cool air bypass damper control servomotor assembly (See page IN-30).

NG

Repair or replace harness or connector.

OK

Check and replace A/C control assembly.