

INSPECTION

1. VEHICLE NOT INVOLVED IN COLLISION

- (a) Do a diagnostic system check. (See page DI-229)
- (b) Do a visual check which includes the following item with the seatback assembly installed in the vehicle.

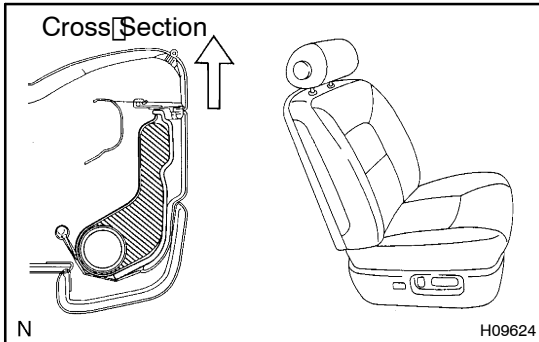

Check that there are no cuts or frayed seams and outside of seatback cover.

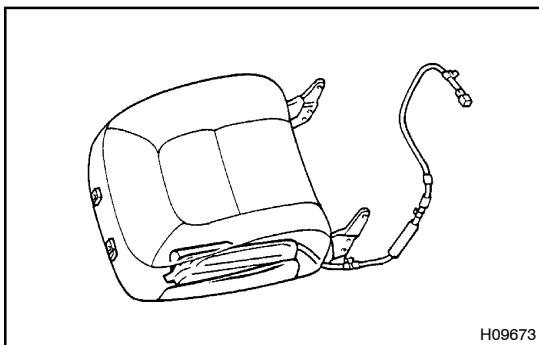

2. VEHICLE INVOLVED IN COLLISION AND AIRBAG IS NOT DEPLOYED

- (a) Do a diagnostic system check. (See page DI-229)
- (b) Do a visual check which includes the following items with the seatback assembly removed from the vehicle.
 - Check cuts and cracks of the front side airbag assembly.
 - Check cuts and cracks in wire harnesses, and chipping in connectors.

CAUTION:

For removal and installation of the seatback assembly, see page RS-38 and RS-48. Be sure to follow the correct procedure.

3. VEHICLE INVOLVED IN COLLISION AND AIRBAG IS DEPLOYED

- (a) Do a diagnostic system check. (See page DI-229)
- (b) Do a visual check which includes the following items with the seatback assembly removed from the vehicle.
 - Check the seatback installation part of the seat adjuster.
 - Check the damage to the connector and wire harness.

HINT:

If the seat adjuster is deformed, never repair it. Always replace it with a new one.